

E3 Modulevel®

Displacer operated level transmitter

DESCRIPTION

E3 Modulevels are 2 wire, loop powered level transmitters utilising buoyancy principle to detect and convert liquid level changes into a stable output signal.

The linkage between the level sensing element and output electronics greatly simplifies mechanical design and construction. The in-line vertical design of the transmitter reduces instrument weight and the effects of process vibration on electronic circuitry components while simplifying installation.

FEATURES

- Operation functions include:
 - interface measurement and detection
 - continuous level measurement
 - density measurement
- 2 line x 8 characters LCD and keypad.
- Easy bench configuration. No need for level simulation.
- Two-wire, intrinsically safe loop powered level transmitter.
- 360° rotatable housing can be dismantled without depressurizing the vessel.
- Special options, materials and custom engineered features.
- Suited for SIL 2 / SIL 3 loops (full FMEDA report and certificate available).

APPLICATIONS

MEDIA: liquids with a S.G. as low as 0,23 up to 2,2 and interfaces with a minimum density difference of 0,10 kg/dm³.

VESSELS: most process vessels up to 445 °C (835 °F) process temperature and pressures up to 355 bar (5150 psi) or storage vessels e.g:

- | | |
|---------------------|------------------------|
| - feedwater heaters | - condensate drip pots |
| - scrubbers | - separators |
| - receivers | - flash tanks |
| - knock out drums | - boilers |

For continuous level, density or liquid-liquid interface

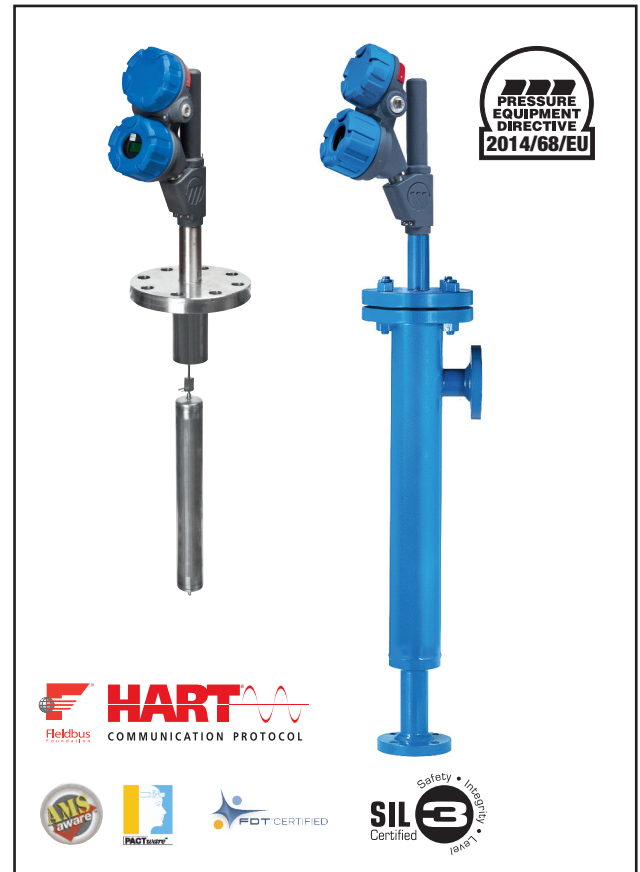

AGENCY APPROVALS

Agency	Approval
ATEX/IEC	II 1G Ex ia II C T4, intrinsically safe II 1/2 G Ex db IIC T6 Ga/Gb, flameproof enclosure
FM explosion proof	Class I Div.1, Groups B,C,D Class II Div.1, Groups E,F,G Class III, Type 4X T5, IP66
FM intrinsically safe	Class I Div.1, Groups A,B,C,D Class II Div.1, Groups E,F,G Class III, Type 4X T4, IP66
LRS	Lloyds Register of Shipment (marine applications)
Russian Authorisation Standards ^①	

^① Consult factory for proper model numbers and classifications.

PRINCIPLE OF OPERATION

Level

Liquid level change acts upon the range spring supported displacer causing vertical motion of a core within a linear variable differential transformer (LVDT).

The enclosing tube acts as a static isolation barrier between the LVDT and the process media.

As core position changes with liquid level, voltages are induced in the secondary windings of the LVDT.

These signals are processed in the electronic circuitry and used to control the output signal.

Interface

E3 Modulelevel is capable of tracking the interface level of two immiscible liquids with different densities. Each unit is custom-made with a displacer specially designed for the user's application. This allows it to detect the position of a clean interface or an emulsion layer and convert it into a stable output signal. Contact the factory for assistance in specifying an E3 for interface service. Note that for proper interface detection, the entire displacer must always be immersed in liquid.

Density

Yet another capability of E3 Modulelevel is to track the changing density of a liquid over a known density range and convert that into a stable output signal. As the density of the liquid changes, so does the mass of the liquid displaced by the specially designed displacer. The resulting change in buoyancy force on the displacer causes the movement of the LVDT core necessary to convert the density change to the output signal.

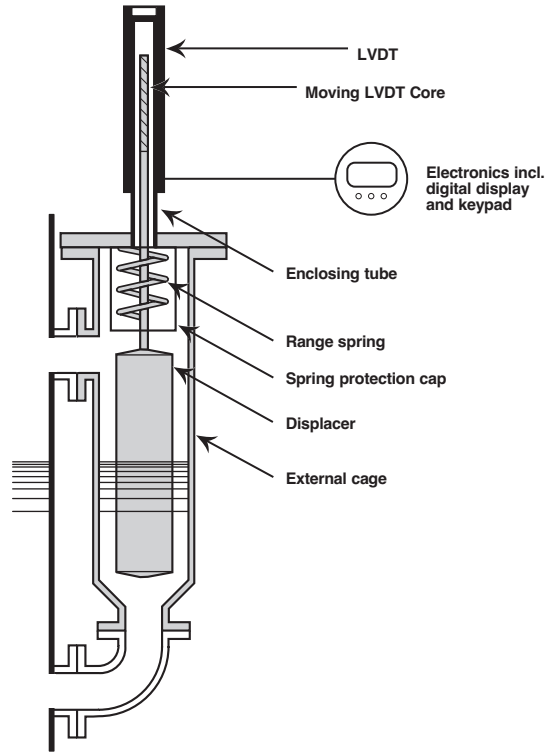

PACTware™ PC SOFTWARE PROGRAM

FDT technology provides an open communication interface between field instruments of various communication protocols and the host/ DCS system. The DTM driver is typical for one type of instrument and delivers the full functionality of the device added with graphical user interface via a laptop or PC. Magnetrol transmitters use the free shareware PACTware™ software to support DTM drivers and the FDT functionality. Via PACTware™ it becomes easy to configure, monitor and diagnose a Magnetrol transmitter from distance or even to call for factory assistance over the internet via the supply of screenshots of on-line parameters and trending graphs. Magnetrol DTM library HART® has passed the dtmINSPECTOR, the official FDT interoperability test and certification tool. The Magnetrol DTM's are free of charge and can be downloaded from www.magnetrol.com.



Magnetrol recommends the VIATOR® USB HART® Interface from MACTek® Corporation.



MOUNTING

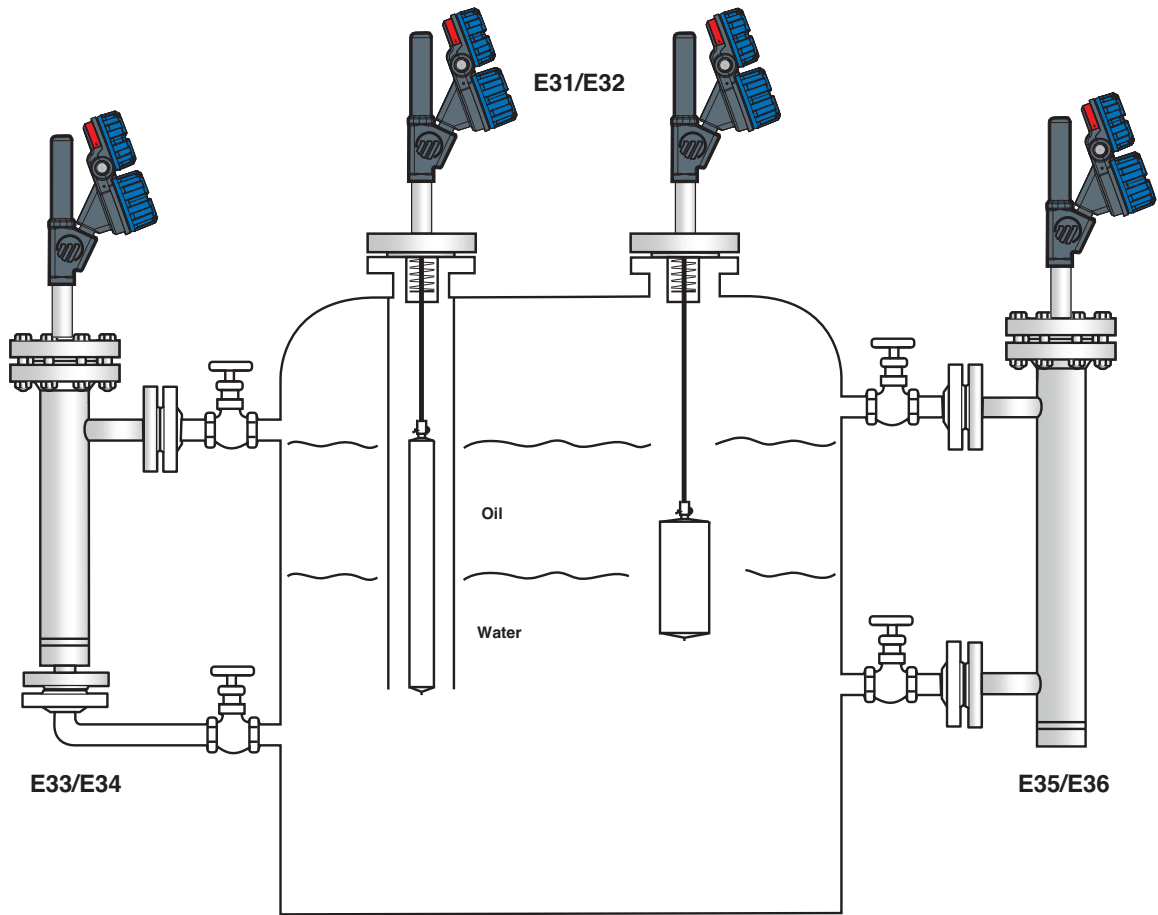

QUICK RESPONSE CELL (QRC)

Several models are available for extra quick shipment, within max. 15 days after factory receipt of purchase order, through the Quick Response Cell (QRC). To take advantage of QRC, simply match the green model number codes.

QRC delivery is limited to a maximum of 10 units per order. Contact your local representative for lead times on larger volume orders, as well as other products and options.

SELECTION DATA

A complete measuring system consists of:

1. One order code for a complete E3 Modulelevel® transmitter.
2. Options:
 - Adjustable displacer hanger for top mounted units, cable length 2,5 m (8'). Required when distance between the top of the displacer and the flange face is > dimension **A** (see section Dimensions) + 60 mm (2.36").

0 3 2 - 3 1 1 0 - 0 0 4 complete order code for adjustable displacer hanger

- Free of charge: E3 Modulelevel DTM (PACTware™) can be downloaded from www.magnetrol.com.
- MACTek Viator USB HART® interface: order code: **070-3004-002**
- Connecting cable used with remote mount electronics (6-wire cable/shielded, not suitable for ATEX/IEC flameproof enclosure). Consult factory for connecting cable suitable for ATEX/IEC flameproof enclosure.

0 0 1 - 0 2 3	From 1 m (3,28 ft) min. to 23 m (75,46 ft) max. Specify in increments of 1 m (3,28 ft)
---------------	---

0 3 7 - 3 M 2 7 -

--	--	--

 complete order code for connecting cable

SELECTION DATA – NON STEAM applications (max 600 lbs)

1 - 3 | BASIC MODEL NUMBER

Carbon steel models

E 3 1	top mounted E3 Module level
E 3 3	E3 Module level with side/bottom cage
E 3 5	E3 Module level with side/side cage

Stainless steel models

E 3 2	top mounted E3 Module level
E 3 4	E3 Module level with side/bottom cage
E 3 6	E3 Module level with side/side cage

4 | SPECIFIC GRAVITY AND PROCESS TEMPERATURE (consult factory for interface applications)

Match temperature extensions with max. process temperature (digit 9)

150 °C	200 °C	230 °C	290 °C	315 °C	445 °C	max. temp. / S.G.
J	A	M	D	M	–	0.23 - 0.54 specific gravity
K	B	N	E	N	E	0.55 - 1.09 specific gravity
L	C	P	F	P	–	1.10 - 2.20 specific gravity

5 6 | PROCESS CONNECTION

For top mounted connection type

E31/E32 - ASME Flange rating					E31/E32 - EN 1092-1 Flange rating				
150 lbs RF	300 lbs RF	600 lbs		Size	PN 16 Type B1	PN 25/40 Type B1	PN 63 Type B2	PN 100 Type B2	Size
		RF	RJ						
G3	G4	G5	GK	3"	EA	EC	ED	EE	DN 80
H3	H4	H5	HK	4"	FA	FC	FD	FE	DN 100
K3	K4	K5	KK	6"	GA	GC	GD	GE	DN 150

For external cage models

E33 ... E36 - ASME Flange/Cage rating					E33 ... E36 - EN 1092-1 Flange rating				
150 lbs RF	300 lbs RF	600 lbs		Size	PN 16 Type B1	PN 25/40 Type B1	PN 63 Type B2	PN 100 Type B2	Size
		RF	RJ						
P3	P4	P5	PK	1 1/2" flanged	CA	CC	CD	CE	DN 40 flanged
Q3	Q4	Q5	QK	2" flanged					
A3	A4	A5		1 1/2" NPT-F					
E3	E4	E5		2" NPT-F	DA	DC	DD	DE	DN 50 flanged
R3	R4	R5		1 1/2" S.W.					
F3	F4	F5		2" S.W.					

7 | LEVEL RANGE

356	813	1219	1524	1829	2134	2438	2743	3048	mm
14	32	48	60	72	84	96	108	120	inches
A	B	C	D	E	F	G	H	I	code

8 | OUTPUT AND ELECTRONICS

S	4-20 mA with Hart®, SIL 2/3 certified (incl. digital display and keypad)
F	FOUNDATION Fieldbus communication (incl. digital display and keypad)

9 | MAX PROCESS TEMPERATURE

Match max. process temperature with temperature extensions (digit 4)

Integral mount electronics

1	T ≤ +290 °C (+550 °F)	– digit 4: ALL
3	+290 °C (+550 °F) < T ≤ +315 °C (+600 °F)	– digit 4: M, N or P

Remote mount electronics

7	+315 °C (+600 °F) < T ≤ +445 °C (+835 °F)	– digit 4: E
---	---	--------------

10 | APPROVALS & HOUSING

Cast aluminium		Stainless Steel		Housing material	
3/4" NPT	M20	3/4" NPT	M20	Cable entry	Approval
J	K	L	M	Weatherproof	
A	B	C	D	ATEX/IEC and FISCO intrinsically safe	
E	F	G	H	ATEX/IEC (Hart and FF) flameproof enclosure	
5	6	7	8	FM and FISCO intrinsically safe	
1	2	3	4	FM (Hart and FF) Explosion proof	



complete order code for E3 Module level transmitter – NON STEAM applications

X = product with a specific customer requirement

SELECTION DATA – STEAM applications (max 600 lbs)

1 - 3 | BASIC MODEL NUMBER

Carbon steel models

E 3 1	top mounted E3 Module level
E 3 3	E3 Module level with side/bottom cage
E 3 5	E3 Module level with side/side cage

Stainless steel models

E 3 2	top mounted E3 Module level
E 3 4	E3 Module level with side/bottom cage
E 3 6	E3 Module level with side/side cage

4 | SPECIFIC GRAVITY AND PROCESS TEMPERATURE (consult factory for interface applications)

Match temperature extensions with max. process temperature (digit 9)

150 °C	200 °C	230 °C	260 °C	max. temp. / S.G.
K	B	N	E	0.55 - 1.09 specific gravity

5 6 | PROCESS CONNECTION

For top mounted connection type

E31/E32 - ASME Flange rating					E31/E32 - EN 1092-1 Flange rating				
150 lbs RF	300 lbs RF	600 lbs		Size	PN 16 Type B1	PN 25/40 Type B1	PN 63 Type B2	PN 100 Type B2	Size
		RF	RJ						
G3	G4	G5	GK	3"	EA	EC	ED	EE	DN 80
H3	H4	H5	HK	4"	FA	FC	FD	FE	DN 100
K3	K4	K5	KK	6"	GA	GC	GD	GE	DN 150

For external cage models

E33 ... E36 - ASME Flange/Cage rating					E33 ... E36 - EN 1092-1 Flange rating				
150 lbs RF	300 lbs RF	600 lbs		Size	PN 16 Type B1	PN 25/40 Type B1	PN 63 Type B2	PN 100 Type B2	Size
		RF	RJ						
P3	P4	P5	PK	1 1/2" flanged	CA	CC	CD	CE	DN 40 flanged
Q3	Q4	Q5	QK	2" flanged					
A3	A4	A5		1 1/2" NPT-F					
E3	E4	E5		2" NPT-F	DA	DC	DD	DE	DN 50 flanged
R3	R4	R5		1 1/2" S.W.					
F3	F4	F5		2" S.W.					

7 | LEVEL RANGE

356	813	1219	1524	1829	2134	2438	2743	3048	mm
14	32	48	60	72	84	96	108	120	inches
A	B	C	D	E	F	G	H	I	code

8 | OUTPUT AND ELECTRONICS

S	4-20 mA with Hart®, SIL 2/3 certified (incl. digital display and keypad)
F	FOUNDATION Fieldbus communication (incl. digital display and keypad)

9 | MAX PROCESS TEMPERATURE

Match max. process temperature with temperature extensions (digit 4)

Integral mount electronics

1	T ≤ +150 °C (+300 °F)	- digit 4: K
2	+150 °C (+300 °F) < T ≤ +230 °C (+450 °F)	- digit 4: B or N
3	+230 °C (+450 °F) < T ≤ +260 °C (+500 °F)	- digit 4: E

10 | APPROVALS & HOUSING

Cast aluminium		Stainless Steel		Housing material	
3/4" NPT	M20	3/4" NPT	M20	Cable entry	Approval
J	K	L	M	Weatherproof	
A	B	C	D	ATEX/IEC and FISCO intrinsically safe	
E	F	G	H	ATEX/IEC (Hart and FF) flameproof enclosure	
5	6	7	8	FM and FISCO intrinsically safe	
1	2	3	4	FM (Hart and FF) Explosion proof	

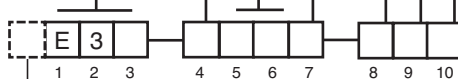

complete order code for E3 Module level transmitter – STEAM applications

X = product with a specific customer requirement

SELECTION DATA – NON STEAM applications (from 900 lbs to 2500 lbs)

1 - 3 | BASIC MODEL NUMBER

Carbon steel models

E 3 1	top mounted E3 Module level
E 3 3	E3 Module level with side/bottom cage
E 3 5	E3 Module level with side/side cage

Stainless steel models

E 3 2	top mounted E3 Module level
E 3 4	E3 Module level with side/bottom cage
E 3 6	E3 Module level with side/side cage

4 | SPECIFIC GRAVITY AND PROCESS TEMPERATURE (consult factory for interface applications)

Match temperature extensions with max. process temperature (digit 9)

150 °C	200 °C	230 °C	290 °C	315 °C	445 °C	max. temp. / S.G.
K	B	N	E	N	E	0.55 - 1.09 specific gravity

5 6 | PROCESS CONNECTION

For top mounted connection type

E31/E32 - ASME Flange rating				Size	E31/E32 - EN 1092-1 Flange rating			Size
900 lbs RJ	1500 lbs RJ	2500 lbs RJ ^①	PN 160 Type B2		PN 250 Type B2	PN 320 Type B2		
GL	–	–	3"	EF	EG	EH	DN 80	
HL	HM	HN	4"	FF	FG	FH	DN 100	
KL	KM	KN	6"	GF	GG	GH	DN 150	

For external cage models

E33...E36 - ASME Flange/Cage rating				Size	E33...E36 - EN 1092-1 Flange rating			Size
900 lbs RJ	1500 lbs RJ	2500 lbs RJ ^①	PN 160 Type B2		PN 250 Type B2	PN 320 Type B2		
PL	PM	PN	1 1/2" flanged	CF	CG	CH	DN 40 flanged	
QL	QM	QN	2" flanged					
AL	AM	AN	1 1/2" NPT-F					
EL	EM	EN	2" NPT-F	DF	DG	DH	DN 50 flanged	
RL	RM	RN	1 1/2" S.W.					
FL	FM	FN	2" S.W.					

^① Max. 355 bar (5150 psig) @ +40 °C (+100 °F)

7 | LEVEL RANGE

356	813	1219	1524	1829	2134	2438	2743	3048	mm
14	32	48	60	72	84	96	108	120	inches
A	B	C	D	consult factory					code

8 | OUTPUT AND ELECTRONICS

S	4-20 mA with Hart®, SIL 2/3 certified (incl. digital display and keypad)
F	FOUNDATION Fieldbus communication (incl. digital display and keypad)

9 | MAX PROCESS TEMPERATURE

Match max. process temperature with temperature extensions (digit 4)

Integral mount electronics

1	T ≤ +290 °C (+550 °F)	– digit 4: ALL
3	+290 °C (+550 °F) < T ≤ +315 °C (+600 °F)	– digit 4: N

Remote mount electronics

7	+315 °C (+600 °F) < T ≤ +445 °C (+835 °F)	– digit 4: E
---	---	--------------

10 | APPROVALS & HOUSING

Cast aluminium		Stainless Steel		Housing material	
3/4" NPT	M20	3/4" NPT	M20	Cable entry	Approval
J	K	L	M	Weatherproof	
A	B	C	D	ATEX/IEC and FISCO intrinsically safe	
E	F	G	H	ATEX/IEC (Hart and FF) flameproof enclosure	
5	6	7	8	FM and FISCO intrinsically safe	
1	2	3	4	FM (Hart and FF) Explosion proof	

complete order code for E3 Module level transmitter –
NON STEAM applications / high pressure



X = product with a specific customer requirement

SELECTION DATA – STEAM applications (from 900 lbs to 2500 lbs)

1 - 3 | BASIC MODEL NUMBER

Carbon steel models

E 3 1	top mounted E3 Module level
E 3 3	E3 Module level with side/bottom cage
E 3 5	E3 Module level with side/side cage

Stainless steel models

E 3 2	top mounted E3 Module level
E 3 4	E3 Module level with side/bottom cage
E 3 6	E3 Module level with side/side cage

4 | SPECIFIC GRAVITY AND PROCESS TEMPERATURE (consult factory for interface applications)

Match temperature extensions with max. process temperature (digit 9)

150 °C	200 °C	230 °C	260 °C	max. temp. / S.G.
K	B	N	E	0.55 - 1.09 specific gravity

5 6 | PROCESS CONNECTION

For top mounted connection type

E31/E32 - ASME Flange rating			Size	E31/E32 - EN 1092-1 Flange rating			Size
900 lbs RJ	1500 lbs RJ	2500 lbs RJ ^①		PN 160 Type B2	PN 250 Type B2	PN 320 Type B2	
GL	–	–	3"	EF	EG	EH	DN 80
HL	HM	HN	4"	FF	FG	FH	DN 100
KL	KM	KN	6"	GF	GG	GH	DN 150

For external cage models

E33...E36 - ASME Flange/Cage rating			Size	E33...E36 - EN 1092-1 Flange rating			Size
900 lbs RJ	1500 lbs RJ	2500 lbs RJ ^①		PN 160 Type B2	PN 250 Type B2	PN 320 Type B2	
PL	PM	PN	1 1/2" flanged	CF	CG	CH	DN 40 flanged
QL	QM	QN	2" flanged				
AL	AM	AN	1 1/2" NPT-F				
EL	EM	EN	2" NPT-F	DF	DG	DH	DN 50 flanged
RL	RM	RN	1 1/2" S.W.				
FL	FM	FN	2" S.W.				

^① Max. 355 bar (5150 psig) @ +40 °C (+100 °F)

7 | LEVEL RANGE

356	813	1219	1524	1829	2134	2438	2743	3048	mm
14	32	48	60	72	84	96	108	120	inches
A	B	C	D	consult factory				code	

8 | OUTPUT AND ELECTRONICS

S	4-20 mA with Hart®, SIL 2/3 certified (incl. digital display and keypad)
F	FOUNDATION Fieldbus communication (incl. digital display and keypad)

9 | MAX PROCESS TEMPERATURE

Match max. process temperature with temperature extensions (digit 4)

Integral mount electronics

1	T ≤ +150 °C (+300 °F)	– digit 4: K
2	+150 °C (+300 °F) < T ≤ +230 °C (+450 °F)	– digit 4: B or N
3	+230 °C (+450 °F) < T ≤ +260 °C (+500 °F)	– digit 4: E

10 | APPROVALS & HOUSING

Cast aluminium		Stainless Steel		Housing material	
3/4" NPT	M20	3/4" NPT	M20	Cable entry	Approval
J	K	L	M	Weatherproof	
A	B	C	D	ATEX/IEC and FISCO intrinsically safe	
E	F	G	H	ATEX/IEC (Hart and FF) flameproof enclosure	
5	6	7	8	FM and FISCO intrinsically safe	
1	2	3	4	FM (Hart and FF) Explosion proof	



complete order code for E3 Module level transmitter – STEAM applications / high pressure

X = product with a specific customer requirement

TRANSMITTER SPECIFICATIONS

FUNCTIONAL/PHYSICAL

Description		Specification
Power (at terminals)		Weatherproof / Intrinsically Safe: 11 to 28,4 V DC (ATEX/IEC) - 28,6 V DC (FM) ATEX/IEC flameproof enclosure 11 to 36 V DC (ATEX/IEC-FM) FOUNDATION Fieldbus™ (FISCO Intrinsically Safe): 9 to 17,5 V DC FOUNDATION Fieldbus™ (Explosion proof): 9 to 32 V DC
Signal Output		4-20 mA with HART®, 3,8 mA to 20,5 mA useable (meets NAMUR NE 43), FOUNDATION Fieldbus™ H1 (ITK Ver. 5)
Span		from 356 mm up to 3048 mm (14" up to 120") - others at request
Resolution		Analog: 0,01 mA Display: 0,1 cm (inch)
Loop Resistance		620 Ω @ 20,5 mA - 24 V DC
Damping		Adjustable 0-45 s
Diagnostic Alarm		Adjustable 3,6 mA, 22 mA, HOLD
User Interface		HART® communicator, AMS® or PACTware®, FOUNDATION Fieldbus™ and keypad
Display		2-line x 8-character LCD
Menu Language		English/Spanish/French/German (FOUNDATION Fieldbus™: English)
Housing Material		IP 66/Aluminium A356T6 (< 0.20 % copper) or stainless steel
Approvals		ATEX/IEC II 1 G Ex ia IIC T4, intrinsically safe ATEX/IEC II 1 G Ex ia IIC T4, FISCO – intrinsically safe ATEX/IEC II 1/2 G Ex db IIC T6 Ga/Gb, flameproof enclosure FM, Intrinsically Safe (FISCO) and explosion proof FOUNDATION Fieldbus™ units are FISCO (intrinsically safe) and ATEX/IEC – FM/CSA explosion proof approved LRS – Lloyds Register of Shipping (marine applications) RosTECH/FSTS – Russian Authorisation Standards
SIL ^① (Safety Integrity Level)		Functional safety to SIL 2 as 1oo1 in accordance to 61508 – SFF of 90,6 % Certified for use in SIL 3 loops.
Electrical Data		U _i = 28,4 V, I _i = 94 mA, P _i = 0,67 W - ATEX/IEC U _i = 28,6 V, I _i = 140 mA, P _i = 1 W - FM U _i = 17,5 V, I _i = 380 mA, P _i = 5,32 W (FOUNDATION Fieldbus)
Equivalent Data		C _i = 2,2 nF, L _i = 3 μH - ATEX/IEC C _i = 5,5 nF, L _i = 9 μH - FM C _i = 0,71 nF, L _i = 3 μH (FOUNDATION Fieldbus™)
Shock/Vibration Class ^②		ANSI/ISA-S71.03 SA1 (Shock), ANSI/ISA-S71.03 VC2 (Vibration)
Net and Gross Weight	Cast aluminium	3 kg (7 lbs) – transmitter head / electronics only
	Stainless steel	8 kg (17 lbs) – transmitter head / electronics only
Overall Dimensions		H 306 mm (12.05") x W 112 mm (4.41") x D 192 mm (7.56")
FOUNDATION Fieldbus™ specifications	ITK Version	5.0
	H1 Device Class	Link Master (LAS) – selectable ON/OFF
	H1 Profile Class	31PS, 32L
	Function Blocks	1 x AI and 1 x PID, 1 x RB, 1 x TB
	Quiescent current draw	17 mA
	Execution time	AI: 15 ms, PID: 40 ms
CFF files		Downloads available from Host system supplier or www.fieldbus.org

^① Not applicable for FOUNDATION Fieldbus™ units.

^② With aluminium housing only. Does not apply to models with stainless steel housing.

PERFORMANCE

Description		Specification
Linearity	Level	± 0,50 % of full span
	Interface/Density	± 0,70 % of full span
Repeatability	Level	± 0,20 % of full span
	Interface/Density	± 0,40 % of full span
Hysteresis		± 0,20 % of full span
Response time		< 1 second
Warm-up Time		< 5 seconds
Ambient Temp.		-40 °C to +80 °C (-40 °F to +175 °F) – electronics temperature range -20 °C to +70 °C (-5 °F to +160 °F) – LCD temperature range -40 °C to +70 °C (-40 °F to +160 °F) – for Ex ia and Ex d units
Storage temperature		-40 °C to +85 °C (-40 °F to +185 °F)
Ambient Temp. Effect		Max zero shift is 0,03 % / °C (0,017 % / °F)
Process Temp.	Max	+260 °C (+500 °F) for steam / + 445 °C (+835 °F) for non steam
	Min	-30 °C (-20 °F) for carbon steel models / -196 °C (-320 °F) for stainless steel models
Max Process Pressure		355 bar @ +40 °C (5150 psi @ +100 °F)
Density Range		from 0,23 kg/dm ³ up to 2,20 kg/dm ³
Humidity		0-99 %, non-condensing
Electromagnetic compatibility		Meets CE requirements (EN 61326: 1997 + A1 + A2)
Surge Protection		Meets CE EN 61326 (1000V)

MECHANICAL SPECIFICATIONS

Description		Specification
Cage materials		carbon steel or 316/316L (1.4401/1.4404) (other materials at request)
Wetted parts	Spring	Inconel® (other materials at request)
	Displacer	316/316L (1.4401/1.4404) or 316 (1.4401)
Process Connection		Threaded: 1 1/2" NPT-F or 2" NPT-F or 1 1/2" Socket Weld or 2" Socket Weld Flanged: Various ASME or EN flanges
Displacer lengths		From 356 mm (14") up to 3048 mm (120") - other lengths at request

ELECTRICAL WIRING

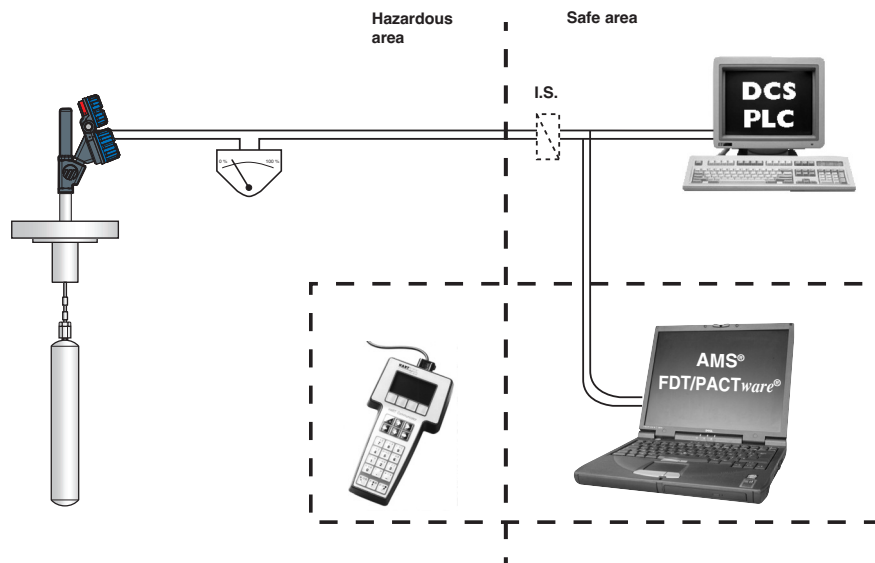

DIMENSIONS in mm (inches)

Transmitter Head

Integral

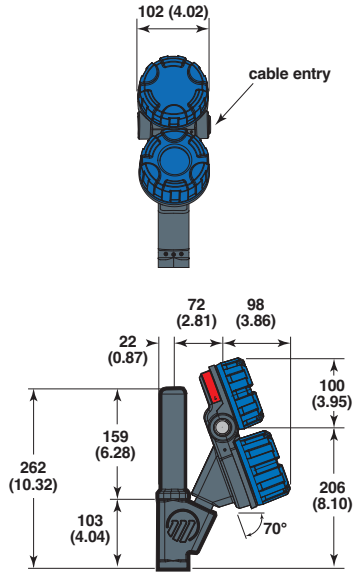

Remote

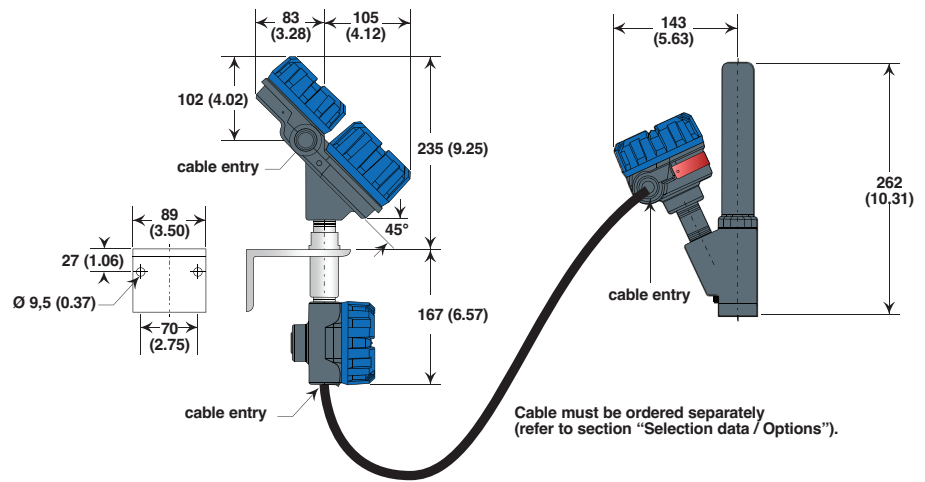

Top Mounted E31/E32 - J/K/L

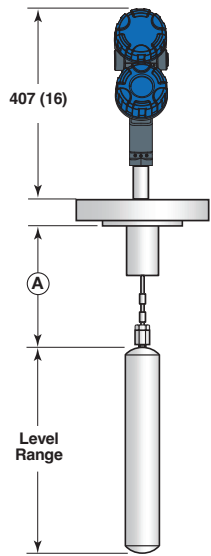

Side/bottom cage E33/E34 - J/K/L

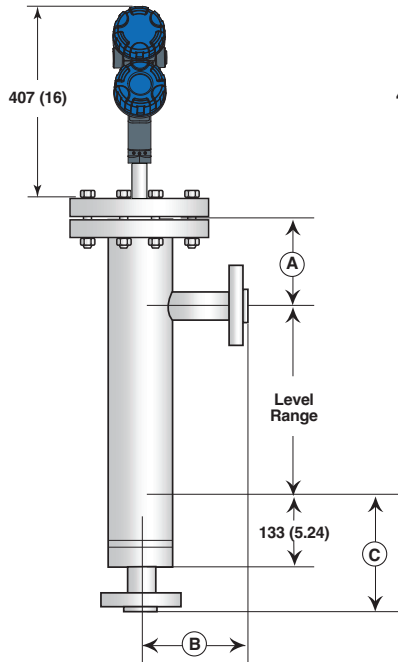

Side/bottom cage E33/E34 - J/K/L

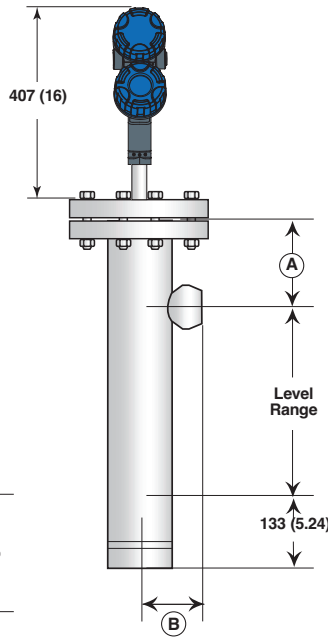

Side/side cage E35/E36 - J/K/L

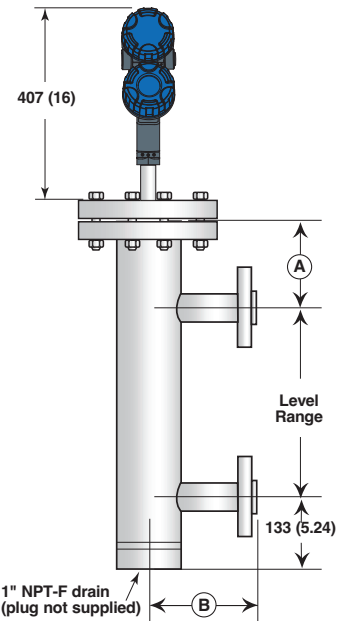

Temperature extensions

Integral

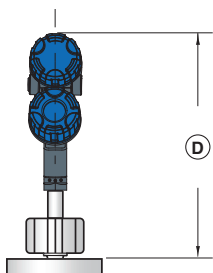

Digit 4	Dim. D
A, B, C	508 (20)
M, N, P	610 (24)
D, E, F	712 (28)

Remote

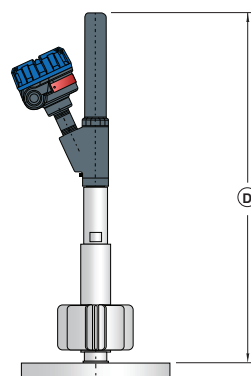

Digit 4	Dim. D
E	668 (26.3)

DIMENSIONS in mm (inches)

Dimension A for all models

Cage rating	SG range	4 th digit	9 th digit	Dimension A
150 / 300 / 600 lbs PN 16 .. PN 100	0.23 - 0.54	J/A/M/D	1/2/3	236 (9.29)
	0.55 - 1.09	K/B/N/E		186 (7.32)
	1.10 - 2.20	L/C/P/F		186 (7.32)
900 / 1500 lbs PN 160 / PN 250	0.55 - 1.09	K/B/N/E	1/2/3	245 (9.65)
2500 lbs PN 320				320 (12.60)
150 / 300 / 600 lbs PN 16 .. PN 100	0.55 - 1.09	E	7	236 (9.29)
900 / 1500 lbs PN 160 / PN 250				245 (9.65)
2500 lbs PN 320				320 (12.60)

Dimensions B and C for external cage models (E33/E34/E35/E36)

Flanged process connections				
Flange size	Flange rating	Connection type	Dimensions	
			B	C
1 1/2"	150 / 300 / 600 lbs	Slip on - ASME RF	180 (7.09)	268 (10.55)
	600 lbs	Weldneck - ASME RJ	180 (7.09)	268 (10.55)
	900 lbs	Weldneck - ASME RJ	195 (7.68)	281 (11.06)
	1500 lbs	Weldneck - ASME RJ	186 (7.32)	281 (11.06)
	2500 lbs	Weldneck - ASME RJ	229 (9.02)	313 (12.32)
2"	150 / 300 / 600 lbs	Slip on - ASME RF	185 (7.28)	273 (10.75)
	600 lbs	Weldneck - ASME RJ	185 (7.28)	273 (10.75)
	900 lbs	Weldneck - ASME RJ	215 (8.46)	302 (11.89)
	1500 lbs	Weldneck - ASME RJ	212 (8.35)	302 (11.89)
	2500 lbs	Weldneck - ASME RJ	250 (9.84)	329 (12.95)
DN 40	PN 16 / PN 25 / PN 40	EN 1092-1 Type B1	180 (7.09)	268 (10.55)
	PN 63 / PN 100	EN 1092-1 Type B2	200 (7.87)	288 (11.34)
	PN 160	EN 1092-1 Type B2	200 (7.87)	consult factory
	PN 250	EN 1092-1 Type B2	consult factory	consult factory
	PN 320	EN 1092-1 Type B2	consult factory	consult factory
DN 50	PN 16	EN 1092-1 Type B1	185 (7.28)	273 (10.75)
	PN 25 / 40	EN 1092-1 Type B1	188 (7.40)	276 (10.87)
	PN 63	EN 1092-1 Type B2	202 (7.95)	293 (11.54)
	PN 100	EN 1092-1 Type B2	208 (8.19)	299 (11.77)
	PN 160	EN 1092-1 Type B2	215 (8.46)	consult factory
	PN 250	EN 1092-1 Type B2	consult factory	consult factory
	PN 320	EN 1092-1 Type B2	consult factory	consult factory

Threaded / Socket weld process connections				
Size	Cage rating	Connection type	Dimensions	
			B	C
1 1/2"	150 / 300 / 600 / 900 lbs	NPT/SW	81 (3.19)	Not Applicable
	1500 lbs	NPT/SW	89 (3.50)	
	2500 lbs	NPT/SW	102 (4.02)	
2"	150 / 300 / 600 / 900 lbs	NPT/SW	84 (3.31)	
	1500 lbs	NPT/SW	98 (3.86)	
	2500 lbs	NPT/SW	111 (4.37)	



QUALITY ASSURANCE - ISO 9001

THE QUALITY ASSURANCE SYSTEM IN PLACE AT MAGNETROL GUARANTEES THE HIGHEST LEVEL OF QUALITY DURING THE DESIGN, THE CONSTRUCTION AND THE SERVICE OF CONTROLS. OUR QUALITY ASSURANCE SYSTEM IS APPROVED AND CERTIFIED TO **ISO 9001** AND OUR TOTAL COMPANY IS COMMITTED TO PROVIDING FULL CUSTOMER SATISFACTION BOTH IN QUALITY PRODUCTS AND QUALITY SERVICE.

PRODUCT WARRANTY

ALL E3 MODULE LEVEL TRANSMITTERS ARE WARRANTED FREE OF DEFECTS IN MATERIALS AND WORKMANSHIP FOR 18 MONTHS FROM THE DATE OF ORIGINAL FACTORY SHIPMENT.

IF RETURNED WITHIN THE WARRANTY PERIOD; AND, UPON FACTORY INSPECTION OF THE CONTROL, THE CAUSE OF THE CLAIM IS DETERMINED TO BE COVERED UNDER THE WARRANTY; THEN, MAGNETROL INTERNATIONAL WILL REPAIR OR REPLACE THE CONTROL AT NO COST TO THE PURCHASER (OR OWNER) OTHER THAN TRANSPORTATION.

MAGNETROL SHALL NOT BE LIABLE FOR MISAPPLICATION, LABOR CLAIMS, DIRECT OR CONSEQUENTIAL DAMAGE OR EXPENSE ARISING FROM THE INSTALLATION OR USE OF THE EQUIPMENT. THERE ARE NO OTHER WARRANTIES EXPRESSED OR IMPLIED, EXCEPT, SPECIAL WRITTEN WARRANTIES COVERING SOME MAGNETROL PRODUCTS.

UNDER RESERVE OF MODIFICATIONS

BULLETIN N°: BE 48-135.6
EFFECTIVE: JULY 2021
SUPERSEDES: January 2021

European Headquarters & Manufacturing Facility

Heikensstraat 6
9240 Zele, Belgium
Tel: +32-(0)52-45.11.11
e-mail: info@magnetrol.be

www.magnetrol.com



MAGNETROL®

AMETEK®
SENSORS, TEST & CALIBRATION