

Fisher™ FIELDVUE™ DLC3010 Digital Level Controller

The FIELDVUE DLC3010 digital level controller is used with level sensors to measure liquid level, the level of the interface between two liquids, or liquid specific gravity (density). Changes in level or specific gravity exert a buoyant force on a displacer, which rotates a torque tube shaft. The digital level controller converts this rotational motion to an electronic signal.

The DLC3010 is a communicating, microprocessor-based instrument that can be configured to sense the level, interface level, or density of liquids. In addition to the normal function of providing a 4 to 20 milliampere current signal, the DLC3010, using HART® communications protocol, gives easy access to information critical to process operation. You can obtain information about the process, instrument, or sensor using an Emerson Field Communicator. The DLC3010 can be used in analog or HART digital signaling mode with the Emerson Automation Solutions DeltaV™ system.

The connection for HART communication may be made at any point in the field wiring that meets the HART impedance requirements. Configuration, calibration, diagnostics, parameter review, signal monitoring and alert monitoring are all available



W7977-2

through the HART protocol. Information from the field can be integrated into control systems or be received on a single loop basis.

The DLC3010 digital level controller is designed to directly replace standard pneumatic and electronic level transmitters. It mounts on a wide variety of Fisher 249 caged and cageless level sensors.

DLC3010 Digital Level Controller Specifications

Available Configurations

DLC3010 Digital Level Controller:
Mounts on caged and cageless 249 sensors. See tables 4 and 5 and sensor description.

Function: Transmitter

Communications Protocol: HART

Input Signal

Level, Interface, or Density: Rotary motion of torque tube shaft proportional to changes in liquid level, interface level, or density that change the buoyancy of a displacer.

Process Temperature: Interface for 2- or 3-wire 100 ohm platinum RTD for sensing process temperature, or optional user-entered target temperature to permit compensating for changes in specific gravity

Output Signal

Analog: 4 to 20 milliamperes DC (■ direct action—increasing level, interface, or density increases output; or ■ reverse action—increasing level, interface, or density decreases output)

High saturation: 20.5 mA

Low saturation: 3.8 mA

High alarm: 22.5 mA

Low Alarm: 3.7 mA

Only one of the above high/low alarm definitions is available in a given configuration. NAMUR NE 43 compliant when high alarm level is selected.

Digital: HART 1200 Baud FSK (frequency shift keyed)

HART impedance requirements must be met to enable communication. Total shunt impedance across the master device connections (excluding the master and transmitter impedance) must be between

230 and 600 ohms. The transmitter HART receive impedance is defined as:

Rx: 42K ohms and

Cx: 14 nF

In point-to-point configuration, analog and digital signalling are available. The instrument may be queried digitally for information, or placed in Burst mode to regularly transmit unsolicited process information digitally. In multi-drop mode, the output current is fixed at 4 mA, and only digital communication is available.

Performance

Performance Criteria	DLC3010 Digital Level Controller ⁽¹⁾	w/ 3-Inch 249W, Using a 14-inch Displacer	w/ All Other 249 Sensors
Independent Linearity	± 0.25% of output span	± 0.8% of output span	± 0.5% of output span
Hysteresis	<0.2% of output span	---	---
Repeatability	± 0.1% of full scale output	± 0.5% of output span	± 0.3% of output span
Dead Band	<0.05% of input span	---	---
Hysteresis plus Deadband	---	<1.0% of output span	<1.0% of output span

NOTE: At full design span, reference conditions.
1. To lever assembly rotation inputs.

Note: At effective proportional band (PB)<100%, linearity, dead band, repeatability, power supply effect, and ambient temperature influence are potentially derated by the factor (100%/PB)

Operating Influences

Power Supply Effect: Output changes <±0.2% of full scale when supply varies between minimum and maximum voltage specifications.

-continued-

Table of Contents

DLC3010 Specifications 2
 Features 7
 Principle of Operation 9
 249 Level Sensor Specifications 10
 249 Level Sensors 10

Installation 12
 Ordering Information 12
 Construction 13
 Heat Insulator 13
 DLC3010 Digital Level Controller 13

DLC3010 Digital Level Controller Specifications (continued)

Transient Voltage Protection: The loop terminals are protected by a transient voltage suppressor. The specifications are as follows:

Pulse Waveform		Max V _{CL} (Clamping Voltage) (V)	Max I _{pp} (Pulse Peak @ Current) (A)
Rise Time (μs)	Decay to 50% (μs)		
10	1000	93.6	16
8	20	121	83

Note: μs = microsecond

Ambient Temperature: The combined temperature effect on zero and span without the 249 sensor is less than 0.03% of full scale per degree Kelvin over the operating range -40 to 80°C (-40 to 176°F)

Process Temperature: The torque rate is affected by the process temperature (see figure 1). The process density may also be affected by the process temperature.

Process Density: The sensitivity to error in knowledge of process density is proportional to the differential density of the calibration. If the differential specific gravity is 0.2, an error of 0.02 specific gravity units in knowledge of a process fluid density represents 10% of span.

Electromagnetic Compatibility

Meets EN 61326-1:2013 and EN 61326-2-3:2006 Immunity—Industrial locations per Table 2 of EN 61326-1 and Table AA.2 of EN 61326-2-3. Performance is shown in table 1 below.
Emissions—Class A
ISM equipment rating: Group 1, Class A

Supply Requirements (See figure 3)

12 to 30 volts DC $\overline{=}$; 22.5 mA
Instrument has reverse polarity protection.
A minimum compliance voltage of 17.75 is required to guarantee HART communication.

Compensation

Transducer compensation: for ambient temperature.
Density parameter compensation: for process temperature (requires user-supplied tables).
Manual compensation: for torque tube rate at target process temperature is possible.

Digital Monitors

Linked to jumper-selected Hi (factory default) or Lo analog alarm signal:
Torque tube position transducer: Drive monitor and

signal reasonableness monitor
User-configurable alarms: Hi-Hi and Lo-Lo Limit process alarms

HART-readable only:

RTD signal reasonableness monitor: When RTD installed

Processor free-time monitor.

Writes-remaining in Non Volatile Memory monitor.

User-configurable alarms: Hi and Lo limit process alarms, Hi and Lo limit temperature alarms, Hi and Lo limit electronics temperature alarms

Diagnostics

Output loop current diagnostic.

LCD meter diagnostic.

Spot specific gravity measurement in level mode: used to update specific gravity parameter to improve process measurement

Digital signal-tracing capability: by review of “troubleshooting variables”, and

Basic trending capability for PV, TV and SV.

LCD Meter Indications

LCD meter indicates analog output on a percent scale bar graph. The meter also can be configured to display:

Process variable in engineering units only.

Percent range only.

Percent range alternating with process variable or Process variable, alternating with process temperature (and degrees of pilot shaft rotation).

Electrical Classification

Pollution Degree IV, Overvoltage Category II per IEC 61010 clause 5.4.2 d

Hazardous Area:

CSA—Intrinsically Safe, Explosion-proof, Division 2, Dust Ignition-proof

FM—Intrinsically Safe, Explosion-proof, Non-incendive, Dust Ignition-proof

ATEX—Intrinsically Safe, Type n, Flameproof

IECEX—Intrinsically Safe, Type n, Flameproof

Refer to tables 8, 9, 10, and 11 for additional approval information.

Electrical Housing:

CSA—Type 4X

FM—NEMA 4X

ATEX—IP66

IECEX—IP66

-continued-

DLC3010 Digital Level Controller Specifications (continued)

Other Classifications/Certifications

CML— Certification Management Limited (Japan)
 CUTR— Customs Union Technical Regulations (Russia, Kazakhstan, Belarus, and Armenia)
 INMETRO— National Institute of Metrology, Standardization, and Industrial Quality (Brazil)
 KTL— Korea Testing Laboratory (South Korea)
 NEPSI— National Supervision and Inspection Centre for Explosion Protection and Safety of Instrumentation (China)
 PESO CCOE— Petroleum and Explosives Safety Organisation - Chief Controller of Explosives (India)
 Contact your [Emerson sales office](#) for classification/certification specific information

Minimum Differential Specific Gravity

With a nominal 4.4 degrees torque tube shaft rotation for a 0 to 100 percent change in liquid level (specific gravity=1), the digital level controller can be adjusted to provide full output for an input range of 5% of nominal input span. This equates to a minimum differential specific gravity of 0.05 with standard volume displacers.

See 249 sensor specifications for standard displacer volumes and standard wall torque tubes. Standard volume for 249C and 249CP is ~980 cm³ (60 in³), most others have standard volume of ~1640 cm³ (100 in³).

Operating at 5% proportional band will degrade accuracy by a factor of 20. Using a thin wall torque tube, or doubling the displacer volume will each roughly double the effective proportional band. When proportional band of the system drops below 50%, changing displacer or torque tube should be considered if high accuracy is a requirement.

Mounting Positions

Digital level controller can be mounted right- or left-of-displacer, as shown in figure 8.

Instrument orientation is normally with the coupling access door at the bottom, to provide proper drainage of lever chamber and terminal compartment, and to limit gravitational effect on the lever assembly. If alternate drainage is provided by user, and a small performance loss is acceptable, the instrument could be mounted in 90 degree rotational

increments around the pilot shaft axis. The LCD meter may be rotated in 90 degree increments to accommodate this.

Construction Materials

Case and Cover: Low-copper aluminum alloy
Internal: Plated steel, aluminum, and stainless steel; encapsulated printed wiring boards; Neodymium Iron Boron Magnets

Electrical Connections

Two 1/2-14 NPT internal conduit connections; one on bottom and one on back of terminal box. M20 adapters available.

Options

- Heat insulator
- Mountings for Masoneilan, Yamatake and Foxboro/Eckhardt displacers available
- Level Signature Series Test (Performance Validation Report) available (EMA only) for instruments factory-mounted on 249 sensor
- Factory Calibration: available for instruments factory-mounted on 249 sensor, when application, process temperature and density(s) are supplied
- Device is compatible with user-specified remote indicator

Operating Limits

Process Temperature: See table 3 and figure 2.
Ambient Temperature and Humidity: See below

Conditions	Normal Limits ⁽¹⁾⁽²⁾	Transport and Storage Limits ⁽¹⁾	Nominal Reference ⁽¹⁾
Ambient Temperature	-40 to 80°C (-40 to 176°F)	-40 to 85°C (-40 to 185°F)	25°C (77°F)
Ambient Relative Humidity	0 to 95%, (non-condensing)	0 to 95%, (non-condensing)	40%

1. LCD meter may not be readable below -20°C (-4°F)
 2. Contact your Emerson sales office or application engineer if temperatures exceeding these limits are required.

Altitude Rating

Up to 2000 meters (6562 feet)

Weight

Less than 2.7 Kg (6 lb)

NOTE: Specialized instrument terms are defined in ANSI/ISA Standard 51.1 - Process Instrument Terminology.

Table 1. EMC Summary Results—Immunity

Port	Phenomenon	Basic Standard	Test Level	Performance Criteria ⁽¹⁾⁽²⁾
Enclosure	Electrostatic discharge (ESD)	IEC 61000-4-2	4 kV contact 8 kV air	A
	Radiated EM field	IEC 61000-4-3	80 to 1000 MHz @ 10V/m with 1 kHz AM at 80% 1400 to 2000 MHz @ 3V/m with 1 kHz AM at 80% 2000 to 2700 MHz @ 1V/m with 1 kHz AM at 80%	A
	Rated power frequency magnetic field	IEC 61000-4-8	60 A/m at 50 Hz	A
I/O signal/control	Burst	IEC 61000-4-4	1 kV	A
	Surge	IEC 61000-4-5	1 kV (line to ground only, each)	B
	Conducted RF	IEC 61000-4-6	150 kHz to 80 MHz at 3 Vrms	A
Note: RTD wiring must be shorter than 3 meters (9.8 feet) 1. A = No degradation during testing. B = Temporary degradation during testing, but is self-recovering. Specification limit = +/- 1% of span. 2. HART communication was considered as "not relevant to the process" and is used primarily for configuration, calibration, and diagnostic purposes.				

Figure 1. Theoretical Reversible Temperature Effect on Common Torque Tube Materials

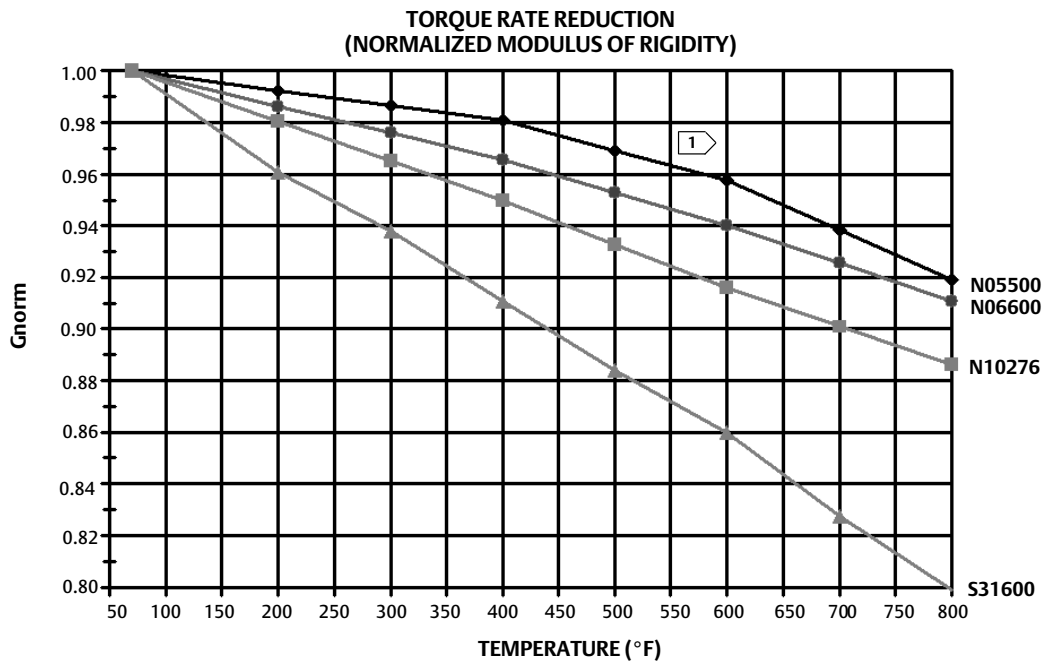
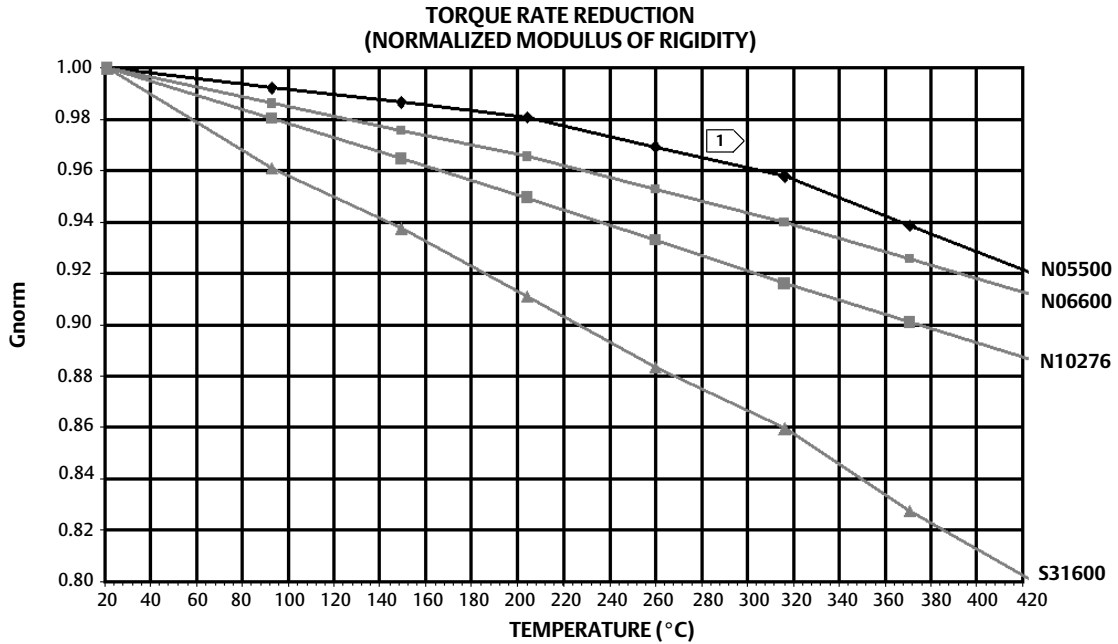

Note:

1 Due to the permanent drift that occurs near and above 260°C (500°F), N05500 is not recommended for temperatures above 232°C (450°F).

Features

- **Simplified Setup and Calibration**—For quick analog transmitter replacement (4-20 mA out only), the instrument may be configured with default sensor data, zero Level Offset, differential process SG, and zero/span procedure only. For full compensation and diagnostic capabilities, complete sensor data entry and calibration is recommended.

Using Guided Setup, digital level controller start-up is straightforward and fast. Level and temperature alarms, specific gravity tables, calibration trim and trending are readily configurable. The DLC3010 also supports re-ranging without a fluid reference.

- **Responsive to Small Process Changes**—Accurate, high-gain analog-to-digital conversion enables measurement of small changes in the process variable. This allows the DLC3010 to be used in difficult liquid level, interface, or density applications. In addition, an adjustable input filter and output damping help to attenuate displacer-induced ripple in the output signal due to liquid turbulence.
- **Reduced Temperature Effects**—An internal temperature sensor enables consistent performance of the digital level controller despite ambient temperature changes. With a temperature input signal, either via HART protocol or an RTD connected to the instrument, the digital level controller can also automatically compensate for specific gravity changes due to temperature. A user-supplied table of up to ten linear segments may be entered to implement this feature. (A sample water/steam table is provided in the DLC3010 instruction manual ([D102748X012](#)). The measured torque tube rate may be manually pre-compensated for a target process temperature using the data available in the DLC3010 Device Description (DD).
- **Additional Compensation**—The instrument measurement algorithm corrects for the small motion of the displacer as buoyancy changes, allowing it to calculate the true cage or vessel level. This provides additional accuracy on the shorter displacers.
- **Rugged Construction**—Mechanical safeguards designed into the digital level controller help it to withstand physical abuse often incurred during installation or in transport, without compromising performance. The fully encapsulated printed wiring boards resist the effects of vibration, temperature, and corrosive atmospheres. The lever assembly is pinned at the neutral position when the coupling access door is open, providing shipping stabilization for a separate transmitter purchase. Locking set screws are provided for covers and the access door handle.
- **Easy Maintenance**—Field wiring connections are in a compartment separated from the electronics. This protects the electronics from any moisture brought into the housing by the field wiring. This also eases installation and maintenance. The digital level controller does not have to be removed to facilitate troubleshooting or service. Modular construction (figure 4) allows servicing in the field. However, if it is necessary to remove the digital level controller for in-shop maintenance and calibration, field wiring does not need to be disconnected.
- **Alarm Jumper**—The DLC3010 digital level controller includes self-diagnostics that detect an error (e.g. electronics failure) that would render the process variable measurement inaccurate. The instrument can also be configured to indicate a process variable high or low alarm. When a process variable alarm or an error is detected the analog output signal is driven either above or below the normal 4 to 20 mA range, depending on the user-selectable position of the alarm jumper. The unit ships from the factory with the jumper in the high position.

Figure 2. Guidelines for Use of Optional Heat Insulator Assembly

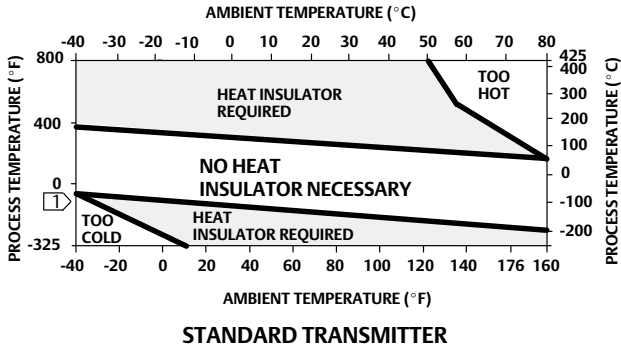

Notes:

1 For process temperature below -29° (C-20°F) and above 204°C (400°F) sensor materials must be appropriate for the process [refer to Fisher Bulletin 34.2:2500 (D200037X012)].

2. If ambient dew point is above process temperature, ice formation might cause instrument malfunction and reduce insulator effectiveness.

39A4070-B
A5494-1

Figure 3. Power Supply Requirements and Load Resistance

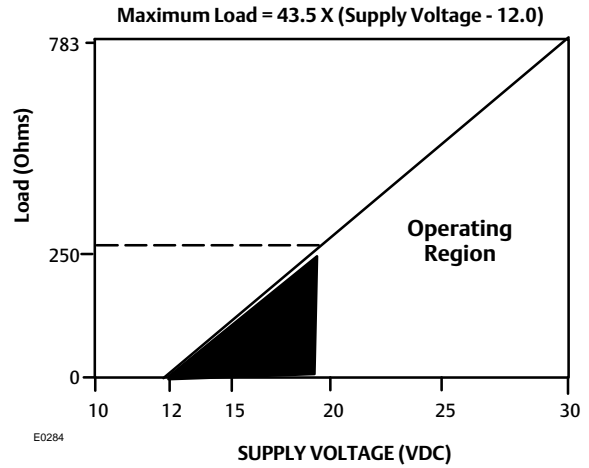
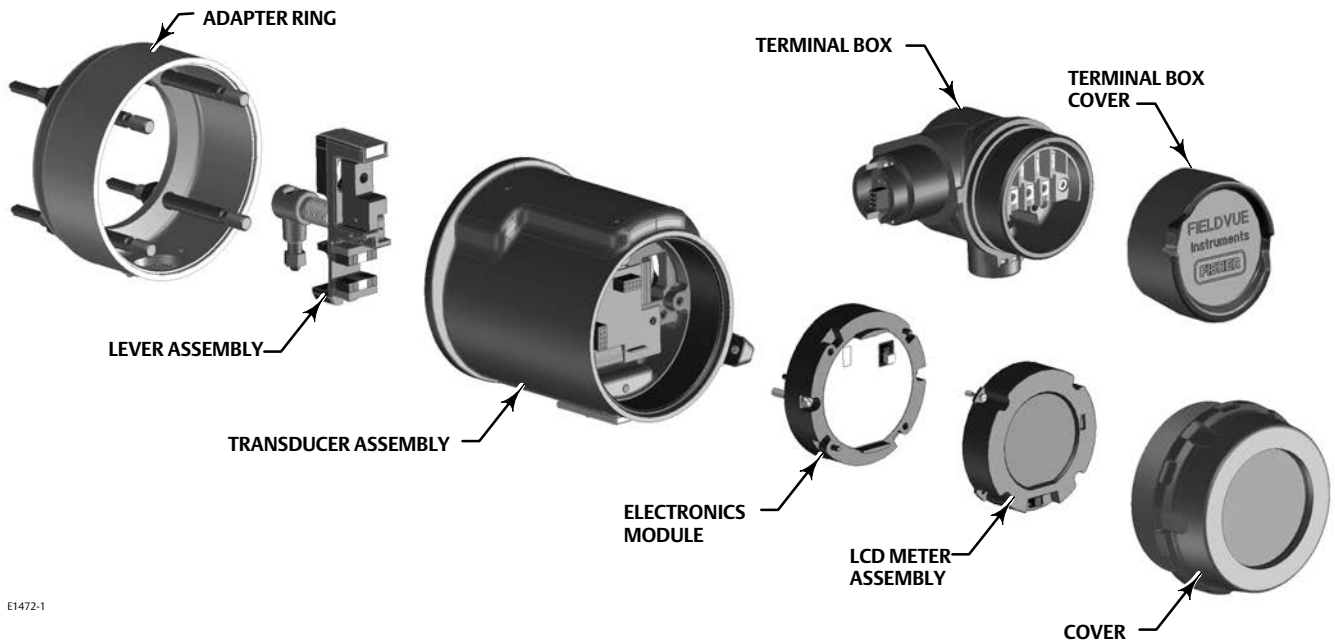

Figure 4. FIELDVUE DLC3010 Digital Level Controller Assembly



E1472-1

Principle of Operation

The DLC3010 digital level controller is a loop-powered instrument that measure changes in liquid level, level of an interface between two liquids, or density of a liquid. A level, density, or interface level change in the measured fluid causes a change in the displacer buoyancy (figure 5). This change is transferred to the torque tube assembly. As the measured fluid changes, the torque tube assembly rotates.

The rotary motion of the torque tube is transferred to the digital level controller lever assembly (figure 5). The rotary motion moves a magnet attached to the lever assembly, changing the magnetic field that is sensed by the Hall-effect sensor. The sensor converts the magnetic field signal to a varying electronic signal, which is processed digitally to provide linearity corrections, sensitivity adjustment, and temperature compensation.

The signal is interpreted as a buoyancy change by reference to the stored torque rate, coupling point, and moment arm data. The buoyancy change in turn is interpreted as a level, interface, or density change by reference to stored displacer volume, specific gravity, and displacer length data. In level or interface modes, the correction for displacer motion is then added, as well as user-supplied offset to change the PV reference from the bottom of the displacer or correct for a coupling point error.

The resultant primary variable (PV) is then compared to PV alarm thresholds (if enabled) and used to set status bits and/or trigger the analog alarm current. If the alarm is not triggered, the PV is used to generate 4-20 mA analog and 0-100% range digital signals by reference to the stored upper and lower range values. The resultant analog command is limited at the saturation values to allow discrimination between saturated and alarm signals.

Figure 5. Cutaway View of Fisher 249 Displacer Sensor with FIELDVUE DLC3010 Digital Level Controller

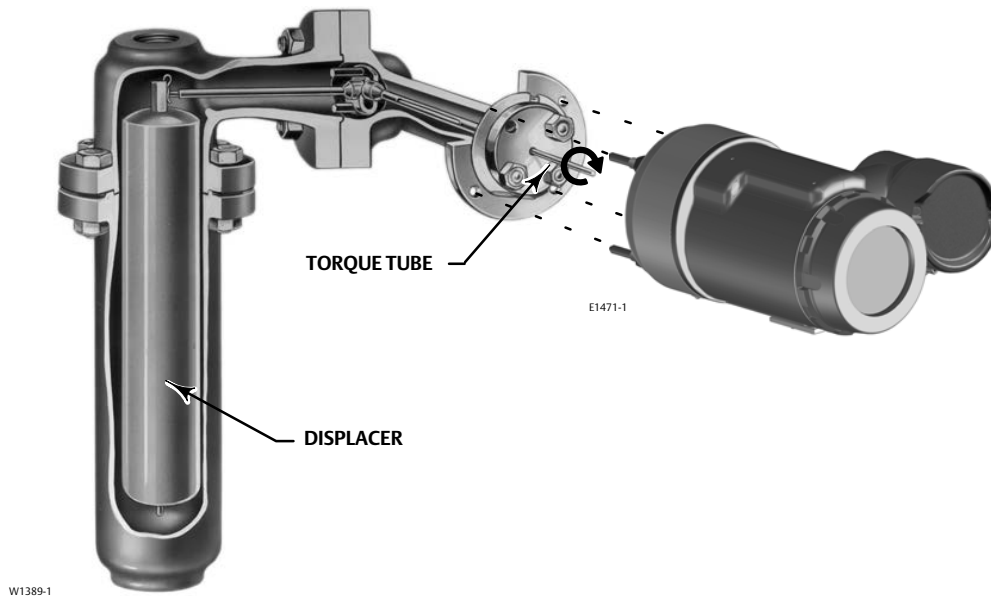

249 Level Sensors Specifications

Input Signal

Liquid Level or Liquid-to-Liquid Interface Level: From 0 to 100 percent of displacer length
Liquid Density: From 0 to 100 percent of displacement force change obtained with given displacer volume—standard volumes are ■ 980 cm³ (60 inches³) for 249C and 249CP sensors or ■ 1640 cm³ (100 inches³) for most other sensors; other volumes available depending upon sensor construction

Sensor Displacer Lengths

See tables 4 and 5 footnotes

Sensor Working Pressures

Consistent with applicable ASME pressure/temperature ratings for the specific sensor constructions shown in tables 4 and 5

Caged Sensor Connection Styles

Cages can be furnished in a variety of end connection styles to facilitate mounting on vessels; the

equalizing connection styles are numbered and are shown in figure 7.

Mounting Positions

Most level sensors with cage displacers have a rotatable head. The head may be rotated through 360 degrees to any of eight different positions, as shown in figure 8.

Construction Materials

See tables 2, 4, and 5

Operative Ambient Temperature

See table 3.
For ambient temperature ranges, guidelines, and use of optional heat insulator, see figure 2.

Options

■ Heat insulator ■ Gauge glass for pressures to 29 bar at 232°C (420 psig at 450°F), and ■ Reflex gauges for high temperature and pressure applications

249 Level Sensors

249 level sensors used with the DLC3010 digital level controller are available in both caged and cageless configurations. Figure 6 shows a DLC3010 mounted on a caged 249 sensor. Caged sensors provide more stable operation than do cageless sensors for vessels with internal obstructions or considerable internal turbulence. Cageless sensors are generally used on specific gravity and interface control applications requiring large displacers that are more easily accommodated by flange connections up to 8 inches. The availability of many different displacer stem lengths permits lowering the displacer down to the most advantageous depth in the vessel.

Figure 6. FIELDVUE DLC3010 Digital Level Controller and Fisher 249B Level Sensor



W7926-1

Table 2. Displacer and Torque Tube Materials

Part	Standard Material	Other Materials
Displacer	304 Stainless Steel	316 Stainless Steel, N10276, N04400, Plastic, and Special Alloys
Displacer Stem, Driver Bearing, Displacer Rod and Driver	316 Stainless Steel	N10276, N04400, other Austenitic Stainless Steels, and Special Alloys
Torque Tube	N05500 ⁽¹⁾	316 Stainless Steel, N06600, N10276

1. N05500 is not recommended for spring applications above 232°C (450°F). Contact your [Emerson sales office](#) or application engineer if temperatures exceeding this limit are required.

Table 3. Allowable Process Temperatures for Common Fisher 249 Sensor Pressure Boundary Materials

MATERIAL	PROCESS TEMPERATURE	
	Min.	Max.
Cast Iron	-29°C (-20°F)	232°C (450°F)
Steel	-29°C (-20°F)	427°C (800°F)
Stainless Steel	-198°C (-325°F)	427°C (800°F)
N04400	-198°C (-325°F)	427°C (800°F)
Graphite Laminate/SST Gaskets	-198°C (-325°F)	427°C (800°F)
N04400/PTFE Gaskets	-73°C (-100°F)	204°C (400°F)

Table 4. Caged Displacer Sensors⁽¹⁾

TORQUE TUBE ORIENTATION	SENSOR	STANDARD CAGE, HEAD, AND TORQUE TUBE ARM MATERIAL	EQUALIZING CONNECTION		PRESSURE RATING ⁽²⁾
			Style	Size (NPS)	
Torque tube arm rotatable with respect to equalizing connections	249 ⁽³⁾	Cast Iron	Screwed	1-1/2 or 2	CL125 or 250
			Flanged	2	
	249B, 249BF ⁽⁴⁾	Steel	Screwed or optional socket weld	1-1/2 or 2	CL600
			Raised face or optional ring type joint flanged	1-1/2	CL150, 300, or 600
	249C ⁽³⁾	316 Stainless Steel	Screwed	1-1/2 or 2	CL600
			Raised face flanged	1-1/2	CL150, 300, or 600
	249K	Steel	Raised face or optional ring type joint flanged	1-1/2 or 2	CL900 or 1500
			249L	Steel	Ring type joint flanged

1. Standard displacer lengths for all styles (except 249) are 14, 32, 48, 60, 72, 84, 96, 108 and 120 inches. The 249 uses a displacer with a length of either 14 or 32 inches.
 2. DIN flange connections available in EMA (Europe, Middle East and Africa).
 3. Not available in EMA.
 4. 249BF available in EMA only. Also available in DIN size DN40 with PN10 to PN100 flanges and size DN50 with PN10 to PN63 flanges.
 5. Top connection is 1-inch ring-type joint flanged for connection styles F1 and F2.

Table 5. Cageless Displacer Sensors⁽¹⁾

Mounting	Sensor	Standard Head ⁽²⁾ , Wafer Body ⁽⁶⁾ , and Torque Tube Arm Material	Flange Connection	Pressure Rating ⁽³⁾
Mounts on top of vessel	249BP ⁽⁴⁾	Steel	NPS 4 raised face or optional ring type joint	CL150, 300, or 600
			NPS 6 or 8 raised face	CL150 or 300
	249CP	316 Stainless Steel	NPS 3 raised face	CL150, 300, or 600
			NPS 4 raised face or optional ring type joint	CL900 or 1500 (EN PN 10 to DIN PN 250)
249P ⁽⁵⁾	Steel or Stainless Steel	NPS 6 or 8 raised face	CL150, 300, 600, 900, 1500, or 2500	
		For NPS 4 raised face or flat face	CL125, 150, 250, 300, 900, or 1500 (EN PN 10 to DIN PN 160)	
Mounts on side of vessel	249VS	Cast Iron, Cast Steel or CF8M (316 Stainless Steel)	For NPS 4 butt weld end, XXS	CL2500
			Mounts on top of vessel or on customer supplied cage	249W
	LCC (steel) or CF8M	For NPS 4 raised face	CL150, 300, or 600	

1. Standard displacer lengths are 14, 32, 48, 60, 72, 84, 96, 108, and 120 inches.
 2. Not used with side-mounted sensors.
 3. DIN flange connections available in EMA (Europe, Middle East and Africa).
 4. Not available in EMA.
 5. 249P available in EMA only.
 6. Wafer Body only applicable to 249W.

Figure 7. Style Number of Equalizing Connections

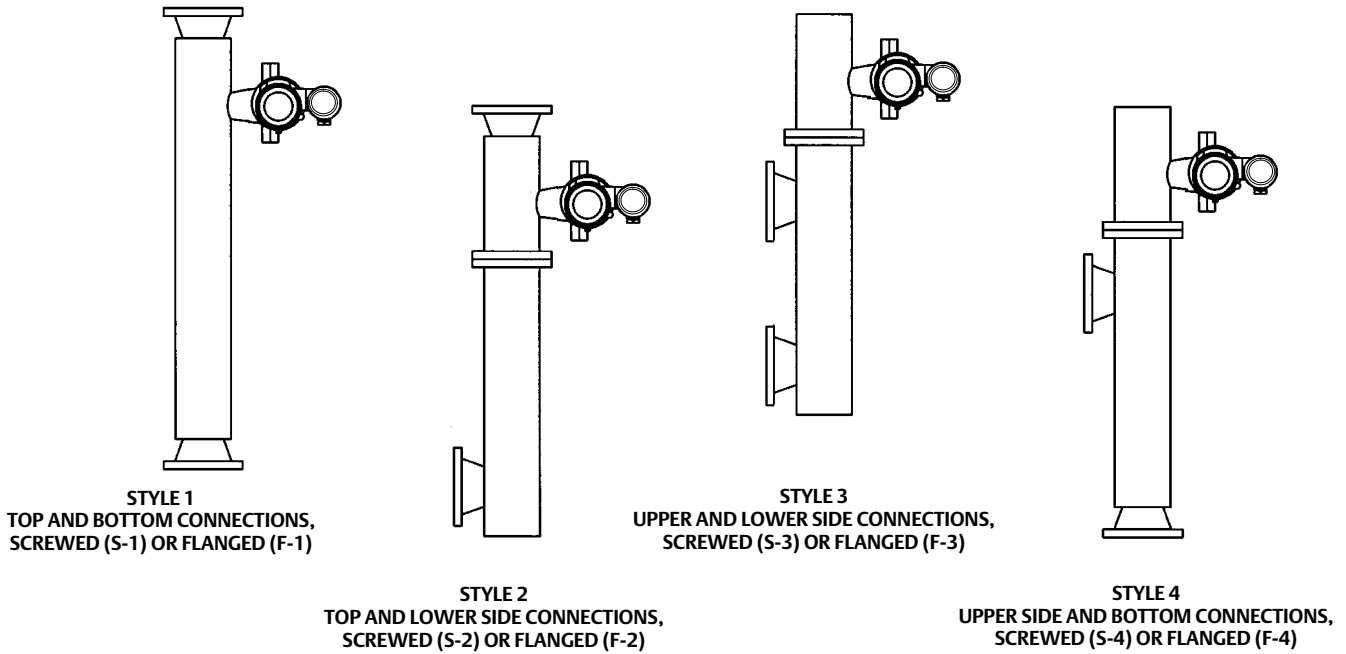

Installation

A 249 sensor may be shipped with the DLC3010 digital level controller installed or they may be shipped separately.

When shipping a skid mounted system, where the displacer cannot be restrained, it is recommended that the transmitter be uncoupled and the lever assembly locked to prevent damage. The transmitter must be re-coupled at commissioning, and a zero-trim will be required.

Dimensions for the DLC3010 and 249 sensor product construction are shown in figure 9 and tables 6 and 7. Dimensions of other combinations are available upon request.

Ordering Information

When ordering, specify:

- Process temperature and pressure and ambient air temperature
- Application
- Liquid level service (specific gravity)
- Interface level service (specific gravity of both liquids and minimum differential gap or span required)
- Density service (minimum and maximum specific gravity required)

Figure 8. Typical Mounting Positions for FIELDVUE DLC3010 Digital Level Controller on Fisher 249 Sensors

SENSOR	LEFT-OF-DISPLACER	RIGHT-OF-DISPLACER
CAGED		
CAGELESS		
<p>1 Not available for 249C and 249K.</p>		

Construction

Refer to the specifications tables. Review the descriptions below each specification and in the referenced tables and figures; specify the desired choice whenever there is a selection to be made.

Heat Insulator

DLC3010 Digital Level Controller

If the DLC3010 and the 249 sensor are ordered as an assembly, and a heat insulator is required for the application, order the heat insulator as a 249 sensor option. If the DLC3010 is ordered separately, the heat insulator is available as a kit.

Figure 9. Dimensions for FIELDVUE DLC3010 Digital Level Controller Mounted on a Fisher 249B Sensor (also see tables 6 and 7)

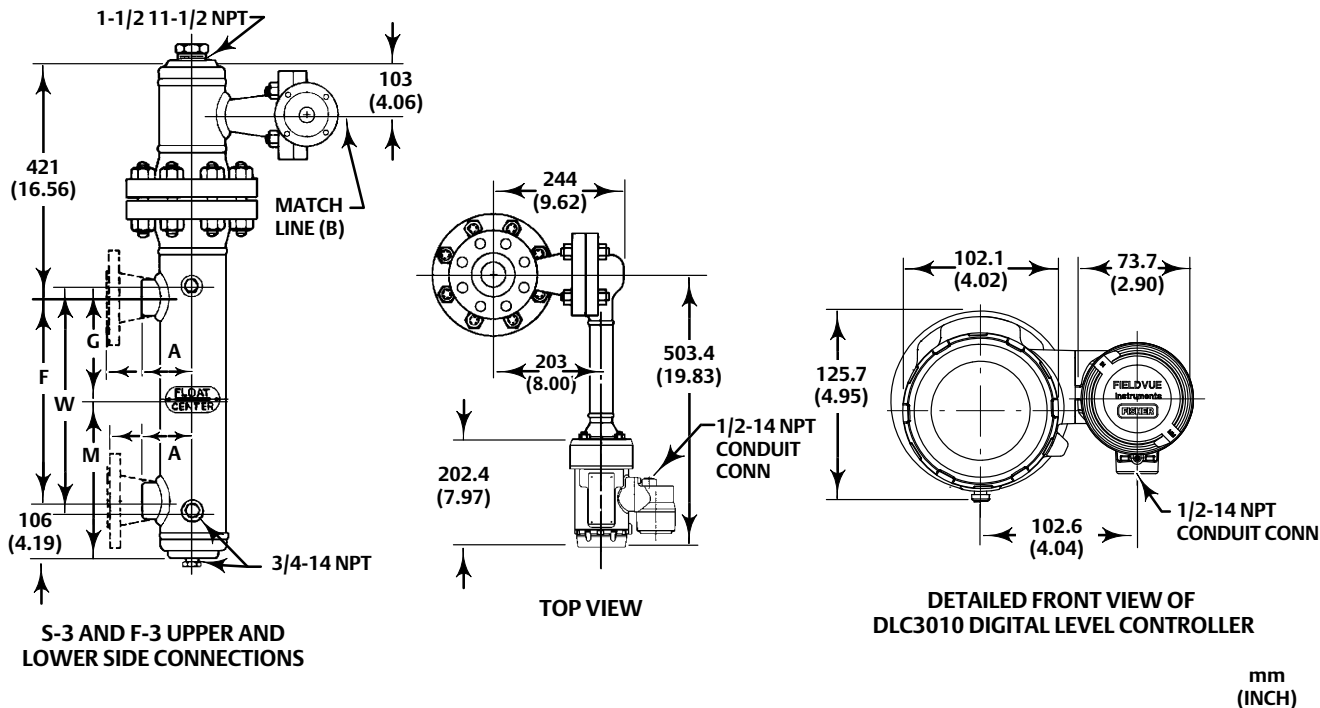

Table 6. Dimension A for FIELDVUE DLC3010 Digital Level Controller Mounted on a Fisher 249B Sensor

SIZE (NPS)	A													
	Screwed NPT		CL150 RF		CL150 RTJ		CL300 RF		CL300 RTJ		CL600 RF		CL600 RTJ	
	mm	Inches	mm	Inches	mm	Inches	mm	Inches	mm	Inches	mm	Inches	mm	Inches
1-1/2	121	4.75	145	5.69	152	6.00	148	5.81	154	6.06	154	6.06	159	6.25
2	121	4.75	145	5.69	151	5.94	148	5.81	155	6.12	157	6.19	159	6.25
DIN ⁽¹⁾														
SIZE	PN10/PN16		PN25/PN40		PN63		PN100							
	mm		mm		mm		mm							
DN40	143		145		153		153							
DN50	145		147		153		---							

1. Dimension A for 249BF with din flanges.

Table 7. Dimensions F, G, M, and W for FIELDVUE DLC3010 Digital Level Controller Mounted on a Fisher 249B Sensor

DISPLACER LENGTH		F		G		M		W	
mm	Inches	mm	Inches	mm	Inches	mm	Inches	mm	Inches
356	14	356	14.00	197	7.75	284	11.19	394	15.50
813	32	813	32.00	425	16.75	513	20.19	851	33.50

Table 8. Hazardous Area Classifications for Canada—CSA

Certification Body	Certification Obtained	Entity Rating	Temperature Code
CSA	Ex ia Intrinsically Safe Class I, Division 1, 2 Groups A, B, C, D Class II, Division 1, 2 Groups E, F, G Class III T6 per drawing 28B5744	V _{max} = 30 VDC I _{max} = 226 mA C _i = 5.5 nF L _i = 0.4 mH	T6 (T _{amb} ≤ 80°C)
	Explosion-proof Class I, Division 1 GP B,C,D T5/T6	---	T5 (T _{amb} ≤ 80°C) T6 (T _{amb} ≤ 78°C)
	Class I Division 2 GP A,B,C,D T5/T6	---	T5 (T _{amb} ≤ 80°C) T6 (T _{amb} ≤ 78°C)
	Class II Division 1, 2 GP E,F,G T5/T6 Class III T5/T6	---	T5 (T _{amb} ≤ 80°C) T6 (T _{amb} ≤ 78°C)

Table 9. Hazardous Area Classifications for United States—FM

Certification Body	Certification Obtained	Entity Rating	Temperature Code
FM	IS Intrinsically Safe Class I,II,III Division 1 GP A,B,C,D,E,F,G T5 per drawing 28B5745	V _{max} = 30 VDC I _{max} = 226 mA P _i = 1.4 W C _i = 5.5 nF L _i = 0.4 mH	T5 (T _{amb} ≤ 80°C)
	XP Explosion-proof Class I Division 1 GP B,C,D T5 NI Non-incendive Class I Division 2 GP A,B,C,D T5 DIP Dust Ignition-proof Class II Division 1 GP E,F,G T5 S Suitable for Use Class II, III Division 2 GP F,G	---	T5 (T _{amb} ≤ 80°C)

Table 10. Hazardous Area Classifications—ATEX

Certificate	Certification Obtained	Entity Rating	Temperature Code
ATEX	Intrinsically Safe Ⓜ II 1 G D Gas Ex ia IIC T5 Ga Dust Ex ia IIIC T83°C Da IP66	U _i = 30 VDC I _i = 226 mA P _i = 1.2 W C _i = 5.5 nF L _i = 0.4 mH	T5 (T _{amb} ≤ 80°C)
	Flameproof Ⓜ II 2 G D Gas Ex d IIC T5 Gb Dust Ex tb IIIC T83°C Db IP66	---	T5 (T _{amb} ≤ 80°C)
	Type n Ⓜ II 3 G D Gas Ex nA IIC T5 Gc Dust Ex t IIIC T83°C Dc IP66	---	T5 (T _{amb} ≤ 80°C)

Table 11. Hazardous Area Classifications—IECEX

Certificate	Certification Obtained	Entity Rating	Temperature Code
IECEX	Intrinsically Safe Gas Ex ia IIC T5 Ga Dust Ex ia IIIC T83°C Da IP66	Ui = 30 VDC Ii = 226 mA Pi = 1.2 W Ci = 5.5 nF Li = 0.4 mH	T5 (Tamb ≤ 80°C)
	Flameproof Gas Exd IIC T6 Gb Dust Ex t IIIC T83°C Db IP66	---	T5 (Tamb ≤ 80°C)
	Type n Gas Ex nA IIC T5 Gc Dust Ex t IIIC T83°C Dc IP66	---	T5 (Tamb ≤ 80°C)

Neither Emerson, Emerson Automation Solutions, nor any of their affiliated entities assumes responsibility for the selection, use or maintenance of any product. Responsibility for proper selection, use, and maintenance of any product remains solely with the purchaser and end user.

Fisher, FIELDVUE, and DeltaV are marks owned by one of the companies in the Emerson Automation Solutions business unit of Emerson Electric Co. Emerson Automation Solutions, Emerson, and the Emerson logo are trademarks and service marks of Emerson Electric Co. HART is a registered trademark of the FieldComm Group. All other marks are the property of their respective owners.

The contents of this publication are presented for informational purposes only, and while every effort has been made to ensure their accuracy, they are not to be construed as warranties or guarantees, express or implied, regarding the products or services described herein or their use or applicability. All sales are governed by our terms and conditions, which are available upon request. We reserve the right to modify or improve the designs or specifications of such products at any time without notice.

Emerson Automation Solutions
Marshalltown, Iowa 50158 USA
Sorocaba, 18087 Brazil
Cernay, 68700 France
Dubai, United Arab Emirates
Singapore 128461 Singapore

www.Fisher.com

