

Rosemount™ 5300 Level Transmitter

Guided Wave Radar



- Industry leading measurement capability and reliability
- Safety certified to IEC 61508 for SIL2 applications
- Increased plant availability with predictive maintenance and easy troubleshooting
- Reduced instrument count and process penetrations with a multivariable transmitter

Taking guided wave radar benefits to the next level

Measurement principle

Low power, nano-second microwave pulses are guided down a probe submerged in the process media. When a microwave pulse reaches a medium with a different dielectric constant, part of the energy is reflected back to the transmitter.

The transmitter uses the residual wave of the first reflection for measuring the interface level. Part of the wave, which was not reflected at the upper product surface, continues until it is reflected at the lower product surface. The speed of this wave depends fully on the dielectric constant of the upper product.

The time difference between the transmitted and the reflected pulse is converted into a distance, and the total level or interface level is then calculated. The reflection intensity depends on the dielectric constant of the product: the higher dielectric constant value, the stronger reflection.

Figure 1: Measurement Principle

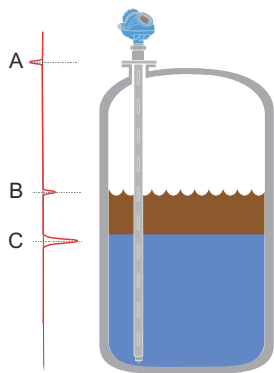

- A. Reference pulse
- B. Level
- C. Interface level

Guided wave radar technology benefits

- Highly accurate and reliable direct level measurement with no compensation needed for changing process conditions (such as density, conductivity, viscosity, pH, temperature, and pressure)
- No moving parts and no re-calibration result in minimized maintenance
- Handles vapor, dust, turbulence, and foam well
- Suitable for small tanks, difficult tank geometry, internal obstacles, and unaffected by the mechanical design of chambers
- Top down installation minimizes risk for leakages

Contents

Taking guided wave radar benefits to the next level.....	2
Ordering information.....	5
Specifications.....	25
Product certifications.....	65
Dimensional drawings.....	81

Special Rosemount 5300 features

Optimized to suit more applications

- Suitable for most liquid and solids level applications and liquid interface applications
- Handles even the most challenging applications reliably, including process vessels, control, and safety systems
- Easy retrofit in existing chambers or available as complete assembly with high quality Rosemount chambers
- Dynamic Vapor Compensation assures accuracy also in saturated steam
- Large coaxial probe optimized for interface applications where there is a need to measure level and interface level all the way up to flange

Best performance and uptime

- Unique Direct Switch Technology and Probe End Projection improve capability and reliability particularly in challenging applications
- Single lead probe for long measuring ranges, obstructions and low dielectrics ensures reliability in more applications, such as viscous media
- Signal processing algorithm makes it possible to distinguish between two liquids with a top layer down to 1 in. (2.5 cm).
- Smart Galvanic Interface results in a more stable microwave and EMI performance with minimized effects from outside disturbances

Robust design and increased safety

- Heavy-duty unique hardware for extreme temperature and pressures with multiple layers of protection
- EchoLogics® and smart software functions provide enhanced ability to keep track of the surface and detect a full vessel situation
- Third party approved for overfill prevention and Safety Integrated System SIL3 suitability
- Electronics and cable connections in separate compartments provides safer handling and improved moisture protection
- Online device verification and reliable detection of high level conditions with the verification reflector

Easy installation and plant integration

- Easy upgrade by matching existing tank connections and cut-to-fit probes
- Long lengths of rigid probes for robust measurements become cost-effective and practical to ship, store and install with the segmented probe option (code 4S)
- Multivariable device reduces the number of process penetrations
- Seamless system integration with HART®, FOUNDATION™ Fieldbus, Modbus®, or IEC 62591 (*WirelessHART®*) with the Emerson Wireless 775 THUM™ Adapter
- Pre-configured or easy configuration in Rosemount Radar Master with a five-step wizard, auto connect, and online help
- Enhanced DD with step-by-step configuration and echo curve capability in tools such as AMS Device Manager, and handheld communicator
- DTM™ with echo curve capability for use in FDT®/DTM compatible configuration tools such as PACTware™, Yokogawa FieldMate/PRM

Minimized maintenance reduces cost

- Easy online troubleshooting with user friendly software, utilizing powerful echo curve and logging tools
- Signal Quality Metrics diagnostics detect product build-up on probe to monitor turbulence, boiling, foam, and emulsions
- Predictive maintenance with advanced diagnostics and Plantweb™ alerts
- Modular design for reduced spare parts and easy replacement of the transmitter housing without opening the tank

Access information when you need it with asset tags

Newly shipped devices include a unique QR code asset tag that enables you to access serialized information directly from the device. With this capability, you can:

- Access device drawings, diagrams, technical documentation, and troubleshooting information in your MyEmerson account
- Improve mean time to repair and maintain efficiency
- Ensure confidence that you have located the correct device
- Eliminate the time-consuming process of locating and transcribing nameplates to view asset information

Ordering information

Rosemount 5301 and 5302 Level and/or Interface in Liquids



Rosemount 5301 and 5302 Guided Wave Radar Level Transmitters provide industry leading measurement capabilities and reliability in liquids. Characteristics include:

- Direct Switch Technology and Probe End Projection to handle low reflective media and long measuring ranges
- Wide range of probe styles, materials, and temperatures and pressures for application flexibility
- HART 4-20 mA, FOUNDATION™ Fieldbus, Modbus, or IEC 62591 (WirelessHART®) with the THUM Adapter (see [Emerson Wireless 775 THUM™ Adapter](#) for details)
- Safety-certified to IEC 61508 (option code QT)
- Advanced diagnostics (option code D01 or DA1)
- Transmitter verification and high level supervision (option code HL1, HL2, or HL3)

Specification and selection of product materials, options, or components must be made by the purchaser of the equipment. See [Material selection](#) for more information on material selection.

CONFIGURE >
VIEW PRODUCT >

Table 1: Rosemount 5301 and 5302 Level and/or Interface in Liquids Ordering Information

The starred options (★) represent the most common options and should be selected for best delivery. The non-starred offerings are subject to additional delivery lead time.

Model	Product description	
5301	Guided Wave Radar Liquid Level or Interface Transmitter (interface available for fully submerged probe)	★
5302	Guided Wave Radar Liquid Level and Interface Transmitter	★
Signal output		
H	4-20 mA with HART communication (default output from factory is HART 5, add option code HR7 for HART 7) (see 4-20 mA HART® (output option code H) for details)	★
F	FOUNDATION Fieldbus (see FOUNDATION™ Fieldbus (output option code F) for details)	★
M	RS-485 with Modbus communication (see Modbus® (output option code M) for details)	★
U	Rosemount 2410 Tank Hub Connectivity	
Housing material		
A	Polyurethane-covered Aluminum (Aluminum alloy A360, maximum 0.6 percent Cu)	★
S	Stainless Steel, Grade CF8M (ASTM A743)	
Conduit / cable threads		Note
1	½ - 14 NPT	1 plug included
2	M20 x 1.5 adapter	1 adapter and 1 plug included
4	2 pcs M20 x 1.5 adapter	2 adapters and 1 plug included
G ⁽¹⁾⁽²⁾	Metal cable gland (½ - 14 NPT)	2 glands and 1 plug included

Table 1: Rosemount 5301 and 5302 Level and/or Interface in Liquids Ordering Information (continued)

E ⁽³⁾	M12, 4-pin, male connector (eurofast [®])		1 plug included	★
M ⁽³⁾	A size Mini, 4-pin, male connector (minifast [®])		1 plug included	★
Operating temperature and pressure (see Process temperature and pressure rating)⁽⁴⁾			Probe type	
Standard (Std)				
S	Design and operating temperature: -40 to 302 °F (-40 to 150 °C)	Design and operating pressure: -15 to 580 psig (-1 to 40 bar)	1A, 2A, 3A, 3B, 3C, 4A, 4B, 4S, 5A, and 5B	★
High Pressure (HP)				
P ⁽⁵⁾	Design temperature: -76 to 752 °F (-60 to 400 °C) ⁽⁶⁾	Design and operating pressure: -15 to 5000 psig (-1 to 345 bar)	3A, 3B, 3C, 4A, 4B, 4S, 5A, and 5B	★
	Operating temperature: -76 to 500 °F (-60 to 260 °C) ⁽⁷⁾			
High Temperature / High Pressure (HTHP)				
H ⁽⁵⁾⁽⁸⁾	Design and operating temperature: -76 to 752 °F (-60 to 400 °C)	Design and operating pressure: -15 to 5000 psig (-1 to 345 bar)	3A, 3B, 3V, 4A, 4B, 4S, 4U, 5A, and 5B	★
Cryogenic Temperature (C)				
C ⁽⁵⁾	Design and operating temperature: -320 to 392 °F (-196 to 200 °C)	Design and operating pressure: -15 to 5000 psig (-1 to 345 bar)	3A, 3B, 3C, 4A, 4B, 4S, 5A, 5B (Only SST)	
Material of construction⁽⁹⁾: Process connection / probe		Probe type	Valid operation temperature and pressure	
1	316/316L/EN 1.4404	All	S, H, P, C	★
2	Alloy C-276 (UNS N10276). With plate design if flanged version. Up to class 600/PN 63 for HTHP/HP probes.	3A, 3B, 4A, 4B, 5A, 5B	S, H, P	
3	Alloy 400 (UNS N04400). With plate design if flanged version.	3A, 3B, 4A, 4B, 5A, 5B	S	
7	PTFE covered probe and flange. With plate design.	4A and 5A	S	
8	PTFE covered probe	4A and 5A	S	
H	Alloy C-276 (UNS N10276) process connection, flange, and probe	3A, 3B, 4A, 4B, 5A, 5B	S, H, P	
D	Duplex 2205 (EN 1.4462/UNS S31803) process connection, flange, and probe	4B, 5A, 5B	S, H, P	
E	Alloy 825 (UNS N08825) process connection, flange, and probe	4B, 5A, 5B	S, H, P	

Table 1: Rosemount 5301 and 5302 Level and/or Interface in Liquids Ordering Information (continued)

Sealing, O-ring material (consult the factory for other O-ring materials)			
N ⁽¹⁰⁾	None		★
V	Viton® Fluoroelastomer		★
E	Ethylene Propylene (EPDM)		★
K	Kalrez® 6375 Perfluoroelastomer		★
B	Nitrile Butadiene (NBR)		★
L ⁽¹¹⁾	Low temperature Viton Fluoroelastomer		
F ⁽¹¹⁾	Fluorsilicone (FVMQ)		
Probe type		Process connections	Probe lengths
3B	Coaxial, perforated. For level and interface measurement.	Flange / 1-in. ⁽¹²⁾ , 1½-in., 2-in. ⁽¹²⁾ Thread	Min: 1 ft. 4 in. (0.4 m) Max: 19 ft. 8 in. (6 m)
3C ⁽¹³⁾	Large coaxial, perforated. For level and interface measurement.	Flange / 1½-in., 2-in. ⁽¹²⁾ Thread	Min: 1 ft. (0.3 m) Max: 19 ft. 8 in. (6 m)
3V ⁽¹⁴⁾⁽¹⁵⁾⁽¹⁶⁾	Integrated Still Pipe Vapor Probe. For 3-in. chambers and above. Refer to "Options" to specify reference reflector length.	Flange	Min: 2 ft. 11 in. (0.9 m) for the short reflector (R1 option) Min: 3 ft. 7 in. (1.1 m) for the long reflector (R2 option) Max: 13 ft. 1 in. (4 m)
4A	Rigid Single Lead (8 mm)	Flange / 1-in. ⁽¹²⁾ , 1½-in., 2-in. ⁽¹²⁾ Thread / Tri Clamp	Min: 1 ft. 4 in. (0.4 m) Max: 9 ft. 10 in. (3 m)
4B	Rigid Single Lead (13mm)	Flange / 1-in., 1½-in., 2-in. Thread / Tri Clamp	Min: 1 ft. 4 in. (0.4 m) Max: 19 ft. 8 in. (6 m)
4U ⁽¹⁴⁾⁽¹⁵⁾⁽¹⁶⁾	Single Rigid Vapor Probe (equip with a 1½-in. centering disc). For 2-in. chambers. Refer to "Options" to specify reference reflector length.	Flange / 1½-in. Thread	Min: 2 ft. 11 in. (0.9 m) for the short reflector (R1 option) Min: 3 ft. 7 in. (1.1 m) for the long reflector (R2 option) Max: 9 ft. 10 in. (3 m)
5A ⁽¹⁷⁾	Flexible Single Lead with weight	Flange / 1-in. ⁽¹²⁾ , 1½-in., 2-in. ⁽¹²⁾ Thread / Tri Clamp	Min: 3 ft. 4 in. (1 m) Max: 164 ft. (50 m) ⁽¹⁸⁾
5B ⁽¹⁹⁾	Flexible Single Lead with chuck	Flange / 1-in. ⁽¹²⁾ , 1½-in., 2-in. ⁽¹²⁾ Thread / Tri Clamp	Min: 3 ft. 4 in. (1 m) Max: 164 ft. (50 m) ⁽¹⁸⁾
1A ⁽¹²⁾	Rigid Twin Lead	Flange / 1½-in., 2-in. ⁽¹²⁾ Thread	Min: 1 ft. 4 in. (0.4 m) Max: 9 ft. 10 in. (3 m)
2A ⁽¹²⁾	Flexible Twin Lead with weight	Flange / 1½-in., 2-in. ⁽¹²⁾ Thread	Min: 3 ft. 4 in. (1 m) Max: 164 ft. (50 m)
3A ⁽²⁰⁾	Coaxial (for level measurement)	Flange / 1-in. ⁽¹²⁾ , 1½-in., 2-in. ⁽¹²⁾ Thread	Min: 1 ft. 4 in. (0.4 m) Max: 19 ft. 8 in. (6 m)

Table 1: Rosemount 5301 and 5302 Level and/or Interface in Liquids Ordering Information (continued)

4S	Segmented Rigid Single Lead (13mm)	Flange / 1-in., 1½-in., 2-in.Thread / Tri Clamp	Min: 1 ft. 4 in. (0.4 m) Max: 32 ft. 9 in. (10 m)	
Probe length units				
E	English (feet, in.)			★
M	Metric (meters, centimeters)			★
Total probe length (feet/m)⁽²¹⁾				
XXX	0-164 ft. or 0-50 m			★
Total probe length (in./cm)⁽²¹⁾				
XX	0-11 in. or 0-99 cm			★
Process connection - size / type (consult the factory for other process connections)				
ASME flanges ⁽²²⁾		Material of construction	Operating temperature and pressure	
AA	2-in. Class 150, RF (Raised Face Type)	1, 2, 3, 7, 8, H, D, E	S, H, P, C	★
AB	2-in. Class 300, RF (Raised Face Type)	1, 2, 3, 7, 8, H, D, E	S, H, P, C	★
AC	2-in. Class 600, RF (Raised Face Type)	1, 2, H, D, E	H, P, C	★
AD	2-in. Class 900, RF (Raised Face Type)	1, H, D, E	H, P, C	★
BA	3-in. Class 150, RF (Raised Face Type)	1, 2, 3, 7, 8, H, D, E	S, H, P, C	★
BB	3-in. Class 300, RF (Raised Face Type)	1, 2, 3, 7, 8, H, D, E	S, H, P, C	★
BC	3-in. Class 600, RF (Raised Face Type)	1, 2, H, D, E	H, P, C	★
BD	3-in. Class 900, RF (Raised Face Type)	1, H, D, E	H, P, C	★
CA	4-in. Class 150, RF (Raised Face Type)	1, 2, 3, 7, 8, H, D, E	S, H, P, C	★
CB	4-in. Class 300, RF (Raised Face Type)	1, 2, 3, 7, 8, H, D, E	S, H, P, C	★
CC	4-in. Class 600, RF (Raised Face Type)	1, 2, H, D, E	H, P, C	★
CD	4-in. Class 900, RF (Raised Face Type)	1, H, D, E	H, P, C	★
AE	2-in. Class 1500, RF (Raised Face Type)	1, H, D, E	H, P, C	
AF	2-in. Class 2500, RF (Raised Face Type)	1	H, P, C	
AI	2-in. Class 600, RTJ (Ring Type Joint)	1, H, D, E	H, P, C	
AJ	2-in. Class 900, RTJ (Ring Type Joint)	1, H, D, E	H, P, C	
AK	2-in. Class 1500, RTJ (Ring Type Joint)	1, H, D, E	H, P, C	
BE	3-in. Class 1500, RF (Raised Face Type)	1, H, D, E	H, P, C	
BF	3-in. Class 2500, RF (Raised Face Type)	1	H, P, C	
BI	3-in. Class 600, RTJ (Ring Type Joint)	1, H, D, E	H, P, C	
BJ	3-in. Class 900, RTJ (Ring Type Joint)	1, H, D, E	H, P, C	
BK	3-in. Class 1500, RTJ (Ring Type Joint)	1, H, D, E	H, P, C	
CE	4-in. Class 1500, RF (Raised Face Type)	1, H, D, E	H, P, C	
CF	4-in. Class 2500, RF (Raised Face Type)	1	H, P, C	
CI	4-in. Class 600, RTJ (Ring Type Joint)	1, H, D, E	H, P, C	

Table 1: Rosemount 5301 and 5302 Level and/or Interface in Liquids Ordering Information (continued)

CJ	4-in. Class 900, RTJ (Ring Type Joint)	1, H, D, E	H, P, C	
CK	4-in. Class 1500, RTJ (Ring Type Joint)	1, H, D, E	H, P, C	
DA	6-in. Class 150, RF (Raised Face Type)	1, 2, 3, 7, 8, H	S, H, P, C	
EN 1092-1 flanges		Material of construction	Operating temperature and pressure	
HB	DN50, PN40, Type A flat face	1, 2, 3, 7, 8	S, H, P, C	★
HC	DN50, PN63, Type A flat face	1, 2, 3	H, P, C	★
HD	DN50, PN100, Type A flat face	1	H, P, C	★
IA	DN80, PN16, Type A flat face	1, 2, 3, 7, 8	S, H, P, C	★
IB	DN80, PN40, Type A flat face	1, 2, 3, 7, 8	S, H, P, C	★
IC	DN80, PN63, Type A flat face	1, 2, 3	H, P, C	★
ID	DN80, PN100, Type A flat face	1	H, P, C	★
JA	DN100, PN16, Type A flat face	1, 2, 3, 7, 8	S, H, P, C	★
JB	DN100, PN40, Type A flat face	1, 2, 3, 7, 8	S, H, P, C	★
JC	DN100, PN63, Type A flat face	1, 2, 3	H, P, C	★
JD	DN100, PN100, Type A flat face	1	H, P, C	★
HE	DN50, PN160, Type B2 raised face	1	H, P, C	
HF	DN50, PN250, Type B2 raised face	1	H, P, C	
HI	DN50, PN40, Type E spigot face	1, 8	S, H, P, C	
HP	DN50, PN16, Type C tongue face	1, 8	S, H, P, C	
HQ	DN50, PN40, Type C tongue face	1, 8	S, H, P, C	
IE	DN80, PN160, Type B2 raised face	1	H, P, C	
IF	DN80, PN250, Type B2 raised face	1	H, P, C	
IH	DN80, PN16, Type E spigot face	1, 8	S, H, P, C	
II	DN80, PN40, Type E spigot face	1, 8	S, H, P, C	
IP	DN80, PN16, Type C tongue face	1, 8	S, H, P, C	
IQ	DN80, PN40, Type C tongue face	1, 8	S, H, P, C	
JE	DN100, PN160, Type B2 raised face	1	H, P, C	
JF	DN100, PN250, Type B2 raised face	1	H, P, C	
JH	DN100, PN16, Type E spigot face	1, 8	S, H, P, C	
JI	DN100, PN40, Type E spigot face	1, 8	S, H, P, C	
JP	DN100, PN16, Type C tongue face	1, 8	S, H, P, C	
JQ	DN100, PN40, Type C tongue face	1, 8	S, H, P, C	
KA	DN150, PN16, Type A flat face	1, 2, 3, 7, 8	S, H, P, C	
JIS flanges		Material of construction	Operating temperature and pressure	
UA	50A, 10K, RF (Raised Face Type)	1, 2, 3, 7, 8	S, H, P, C	★

Table 1: Rosemount 5301 and 5302 Level and/or Interface in Liquids Ordering Information (continued)

VA	80A, 10K, RF (Raised Face Type)	1, 2, 3, 7, 8	S, H, P, C	★
XA	100A, 10K, RF (Raised Face Type)	1, 2, 3, 7, 8	S, H, P, C	★
UB	50A, 20K, RF (Raised Face Type)	1, 2, 3, 7, 8	S, H, P, C	
VB	80A, 20K, RF (Raised Face Type)	1, 2, 3, 7, 8	S, H, P, C	
XB	100A, 20K, RF (Raised Face Type)	1, 2, 3, 7, 8	S, H, P, C	
YA	150A, 10K, RF (Raised Face Type)	1, 2, 3, 7, 8	S, H, P, C	
YB	150A, 20K, RF (Raised Face Type)	1, 2, 3, 7, 8	S, H, P, C	
ZA	200A, 10K, RF (Raised Face Type)	1, 2, 3, 7, 8	S, H, P, C	
ZB	200A, 20K, RF (Raised Face Type)	1, 2, 3, 7, 8	S, H, P, C	
Threaded connections		Material of construction	Probe type	
RA	1½-in. NPT thread	1, 2, 3, 8, H, D	1A, 2A, 3A, 3B, 3C, 4A, 4B, 4S, 4U, 5A, 5B	★
RC	2-in. NPT thread	1, 8	1A, 2A, 3A, 3B, 3C, 4A, 4B, 4S, 5A, 5B, standard temperature and pressure	★
RB	1-in. NPT thread	1, 8	3A, 3B, 4A, 4B, 4S, 5A, 5B, standard temperature and pressure	
SA	1½-in. BSP (G 1½-in.) thread	1, 2, 3, 8, H, D	1A, 2A, 3A, 3B, 3C, 4A, 4B, 4S, 4U, 5A, 5B	
SB	1-in. BSP (G 1-in.) thread	1, 8	3A, 3B, 4A, 4B, 4S, 5A, 5B, standard temperature and pressure	
Tri Clamp fittings		Material of construction	Probe type	
FT	1½-in. Tri Clamp	1, 7, 8	4A, 5A, 5B standard temperature and pressure	
AT	2-in. Tri Clamp	1, 7, 8	4A, 4B, 5A, 5B, 4S standard temperature and pressure	
BT	3-in. Tri Clamp	1, 7, 8	4A, 4B, 5A, 5B, 4S standard temperature and pressure	
CT	4-in. Tri Clamp	1, 7, 8	4A, 4B, 5A, 5B, 4S standard temperature and pressure	
Proprietary flanges				
TF	Fisher - proprietary 316/316L (for 249B, 259B chambers) Torque Tube Flange	1, 7, 8	S, H, P, C	★
TT	Fisher - proprietary 316/316L (for 249C chambers) Torque Tube Flange	1, 7, 8	S, H, P, C	★
TM	Masoneilan - proprietary 316/316L Torque Tube Flange	1, 7, 8	S, H, P, C	★

Table 1: Rosemount 5301 and 5302 Level and/or Interface in Liquids Ordering Information (continued)

Hazardous locations certifications (see Product certifications)		
NA	No Hazardous Locations Certifications	★
E1 ⁽²³⁾	ATEX Flameproof	★
E3 ⁽²³⁾	China Flameproof	★
E5 ⁽²³⁾	USA Explosion-proof	★
E6 ⁽²³⁾	Canadian Explosion-proof	★
E7 ⁽²³⁾	IECEX Flameproof	★
I1	ATEX Intrinsic Safety	★
IA ⁽²⁴⁾	ATEX FISCO Intrinsic Safety	★
I3	China Intrinsic Safety	★
IC ⁽²⁴⁾	China FISCO Intrinsic Safety	★
I5	USA Intrinsic Safety and Non-Incendive	★
IE ⁽²⁴⁾	USA FISCO Intrinsic Safety	★
I6	Canadian Intrinsic Safety	★
IF ⁽²⁴⁾	Canadian FISCO Intrinsic Safety	★
I7	IECEX Intrinsic Safety	★
IG ⁽²⁴⁾	IECEX FISCO Intrinsic Safety	★
E2 ⁽²³⁾	INMETRO Flameproof	
EM ⁽²³⁾	Technical Regulations Customs Union (EAC) Flameproof	
I2	INMETRO Intrinsic Safety	
IB ⁽²⁴⁾	INMETRO FISCO Intrinsic Safety	
IM	Technical Regulations Customs Union (EAC) Intrinsic Safety	
IN ⁽²⁴⁾	Technical Regulations Customs Union (EAC) FISCO Intrinsic Safety	
E4 ⁽²³⁾	Japan Flameproof	
EP ⁽²³⁾ ⁽²⁵⁾	Republic of Korea Flameproof	
KA ⁽²³⁾	ATEX, USA, Canadian Flameproof/Explosion-proof	
KB ⁽²³⁾	ATEX, USA, IECEX Flameproof/Explosion-proof	
KC ⁽²³⁾	ATEX, Canadian, IECEX Flameproof/Explosion-proof	
KD ⁽²³⁾	USA, Canadian, IECEX Flameproof/Explosion-proof	
KE	ATEX, USA, Canadian Intrinsic Safety	
KF	ATEX, USA, IECEX Intrinsic Safety	
KG	ATEX, Canadian, IECEX Intrinsic Safety	
KH	USA, Canadian, IECEX Intrinsic Safety	
KI ⁽²⁴⁾	FISCO - ATEX, USA, Canadian Intrinsic Safety	
KJ ⁽²⁴⁾	FISCO - ATEX, USA, IECEX Intrinsic Safety	
KK ⁽²⁴⁾	FISCO - ATEX, Canadian, IECEX Intrinsic Safety	

Table 1: Rosemount 5301 and 5302 Level and/or Interface in Liquids Ordering Information (continued)

KL ⁽²⁴⁾	FISCO - USA, Canadian, IECEx Intrinsic Safety	
N1	ATEX Type n	
N7	IECEX Type n	
Options (include with selected model number)		
Display		
M1	Integral digital display	★
Communication		
HR7	4–20 mA with digital signal based on HART 7 protocol	★
Hydrostatic testing		
P1 ⁽²⁶⁾	Hydrostatic testing	★
Factory configuration		
C1	Factory configuration (Configuration Data Sheet required with order, available at Emerson.com/Rosemount)	★
Alarm limit configuration		
C4	Namur alarm and saturation levels, high alarm	★
C5	Namur alarm and saturation levels, low alarm	★
C8 ⁽²⁷⁾	Low alarm (standard Rosemount alarm and saturation levels)	★
Welding documentation ⁽²⁸⁾		
Q66	Welding Procedure Qualification Record Documentation	★
Q67	Welder Performance Qualification Record	★
Q68	Welding Procedure Specification	★
Special certifications		
Q4	Calibration Data Certification	★
Q8 ⁽²⁹⁾	Material Traceability Certification consistent with ISO10474-3.1:2013 / EN10204-3.1:2004	★
QG	Calibration Certificate and GOST Verification Certificate (only for end-destination country Russia)	
Safety certifications		
QS	Prior-use certificate of FMEDA Data. Only available with HART 4-20 mA output (output code H).	★
QT	Safety-certified to IEC 61508 with certificate of FMEDA data. Only available with HART 4-20 mA output (output code H).	★
Country certification		
J1	Canadian Registration Number (CRN)	★
J2 ⁽³⁰⁾	ASME B31.1	★
J7 ⁽³¹⁾	Indian Boiler Regulation (For witnessed Form III-C from factory, order certificate Q47 on separate line item)	
J8 ⁽³²⁾⁽³³⁾	EN Boiler (European Boiler Approval in accordance with EN 12952-11 and EN 12953-9)	★
Dye penetration test certificate		
Q73	Certificate of Liquid Penetrant Inspection	★

Table 1: Rosemount 5301 and 5302 Level and/or Interface in Liquids Ordering Information (continued)

Positive material identification certificate		
Q76	Positive Material Identification Certificate of Conformance	★
Materials certification		
NZ ⁽³⁴⁾	NACE [®] material recommendation per NACE MR0175/ISO 15156 and NACE MR0103/ISO 17945	★
Marine / shipboard approvals⁽³⁵⁾		
SBS	American Bureau of Shipping Type Approval	
SDN	Det Norske Veritas Germanischer Lloyd (DNV GL) Type Approval	
SLL	Lloyd's Register Type Approval	
SKR	Korean Register Type Approval	
SBV	Bureau Veritas Type Approval	
SNK	Nippon Kaiji Kyokai Type Approval	
Installation options		
LS ⁽³⁶⁾	Long stud 9.8 in (250 mm) for flexible single lead probe to prevent contact with wall/nozzle. Standard stud length is 3.9 in (100 mm) for probes 5A and 5B.	★
BR	316L Mounting Bracket for 1½-in. NPT Process Connection (RA) (see Figure 48)	
HS ⁽³⁷⁾	Heat sink	
Weight and anchoring options for flexible single probes (probe type 5A)		
W3	Heavy weight (recommended choice for most applications) Weight=2.43 lb (1.10 kg), Length=5.5 in. (140 mm), Diameter=1.5 in. (37.5 mm)	★
W2	Short weight (when measuring close to the probe end) Weight=0.88 lb (0.40 kg). Length=2 in. (50 mm), Diameter=1.5 in. (37.5 mm)	
Weight assembly options for flexible single probes		
WU	Weight or chuck not mounted on the probe	★
Transient protection		
T1	Transient Protection Terminal Block. Selectable with HART 4-20 mA output (output code H). Already included in all FOUNDATION Fieldbus variations.	★
Diagnostic functionality		
D01	FOUNDATION Fieldbus Diagnostics Suite (includes Signal Quality Metrics diagnostics)	★
DA1	HART Diagnostics Suite (includes Signal Quality Metrics diagnostics)	★
Cold temperature		
BR5 ⁽³⁸⁾⁽³⁹⁾⁽⁴⁰⁾⁽⁴¹⁾	-67 °F (-55 °C) cold temperature	
Verification reflectors (high level supervision)		
HL1 ⁽⁴²⁾	Verification reflector for 3- to 6-in. pipe/chamber (High Level Supervision). See Verification reflector (option code HL1, HL2, or HL3) for details.	
HL2 ⁽⁴²⁾	Verification reflector for 8-in. pipe/chamber (High Level Supervision). See Verification reflector (option code HL1, HL2, or HL3) for details.	
HL3 ⁽⁴²⁾	Verification reflector for tanks and 10-in. or wider pipe/chamber (High Level Supervision). See Verification reflector (option code HL1, HL2, or HL3) for details.	

Table 1: Rosemount 5301 and 5302 Level and/or Interface in Liquids Ordering Information (continued)

Overfill prevention		
U1	WHG Overfill Approval	★
Extended product warranty		
WR3 ⁽⁴³⁾	3-year limited warranty	★
WR5 ⁽⁴³⁾	5-year limited warranty	★
Centering discs (see Table 35 for size recommendation)		Outer diameter
S2 ⁽⁴⁴⁾	2-in. Centering disc	1.8 in. (45 mm)
S3 ⁽⁴⁴⁾	3-in. Centering disc	2.7 in. (68 mm)
S4 ⁽⁴⁴⁾	4-in. Centering disc	3.6 in. (92 mm)
P2 ⁽⁴⁵⁾	2-in. Centering disc PTFE	1.8 in. (45 mm)
P3 ⁽⁴⁵⁾	3-in. Centering disc PTFE	2.7 in. (68 mm)
P4 ⁽⁴⁵⁾	4-in. Centering disc PTFE	3.6 in. (92 mm)
S6 ⁽⁴⁴⁾	6-in. Centering disc	5.55 in. (141 mm)
S8 ⁽⁴⁴⁾	8-in. Centering disc	7.40 in. (188 mm)
P6 ⁽⁴⁵⁾	6-in. Centering disc PTFE	5.55 in. (141 mm)
P8 ⁽⁴⁵⁾	8-in. Centering disc PTFE	7.40 in. (188 mm)
Remote housing mounting ⁽⁴⁶⁾ (see Figure 49)		
B1	1 m / 3.2 ft. Remote Housing Mounting Cable and 316L Bracket	
B2	2 m / 6.5 ft. Remote Housing Mounting Cable and 316L Bracket	
B3	3 m / 9.8 ft. Remote Housing Mounting Cable and 316L Bracket	
Reference reflectors for dynamic vapor compensation probes (required for probe type 3V and 4U) (See Select reference reflector for reflector length guidelines)		
R1	Short reflector. Length=14 in. (350 mm)	
R2	Long reflector. Length=20 in. (500 mm)	
Consolidate to chamber (see Rosemount chamber)		
XC ⁽⁴⁷⁾	Consolidate to Chamber	
Engineered solutions (see Engineered solutions)		
Rxxxx	Engineered Solutions beyond standard model codes. (Consult factory for details)	
Example model string: 5301-H-A-1-S-1-V-1A-M-002-05-AA-I1-M1C1 E-002-05, means 2 ft. and 5 in. probe length. M-002-05, means 2.05 m.		

- (1) Not available with explosion-proof or flameproof approvals.
- (2) Minimum temperature is -20 °C (-4 °F).
- (3) Not available with explosion-proof, flameproof, or type n approvals.
- (4) Process seal rating. Final rating depends on Material of construction, Flange and O-ring selection. See “Temperature and pressure limits” on [Process temperature and pressure rating, Flange rating, Tri Clamp rating, and Plate design](#).
- (5) Requires option None for sealing (no O-ring).
- (6) Pressure retaining parts are designed for up to 752 °F (400 °C), maximum operating temperature is 500 °F (260 °C).
- (7) Maximum operating temperature is 482 °F (250 °C) for option code U1, or end-destination countries within the EAC Economic Union (Russia, Belarus, Kazakhstan, Armenia, and Kyrgyzstan).
- (8) For applications where a large amount of contamination is present a standard or high pressure seal should be used, if process conditions allow.
- (9) For other materials, consult the factory.

- (10) Requires Operating Temperature and Pressure code H, P, or C.
- (11) Only available for Probe Type code 3C.
- (12) Only available with Operating Temperature and Pressure code S.
- (13) Requires firmware version 2.L3 or later.
- (14) Only available with Operating Temperature and Pressure code H.
- (15) Not available with Remote housing code B1 or B2.
- (16) Probe type 3V or 4U together with flanges Class 1500/PN160 or higher requires installation option code HS (Heat sink).
- (17) 0.79 lb (0.36 kg) standard weight for flexible single lead probe. L=5.5 in. (140 mm). For PTFE covered probes: 2.2 lb (1 kg) standard weight for flexible single lead probe. L=17.1 in. (434 mm).
- (18) Maximum probe length for Duplex 2205 probes is 105 ft (32 m).
- (19) Extra length for fastening is added in factory.
- (20) Requires model 5301.
- (21) Probe weight included if applicable. Give the total probe length in feet and inches or meters and centimeters, depending on selected probe length unit. If tank height is unknown, please round up to an even length when ordering. Probes can be cut to exact length in field. Maximum allowable length is determined by process conditions. See [Total probe length](#) for more probe length guidance.
- (22) Design according to ASME B31.1. No code stamp or ASME certificate available.
- (23) Probes are intrinsically safe.
- (24) Requires FOUNDATION Fieldbus signal output (U_i parameter listed in [Product certifications](#)).
- (25) The EP (Republic of Korea Flameproof) certificate is based on the E7 (IECEx Flameproof) certificate, therefore model code E7 is stated in the certificate instead of EP.
- (26) Available for tank connection with flange.
- (27) The standard alarm setting is high.
- (28) Weldings in accordance with EN/ISO standards.
- (29) Certificate includes all pressure retaining wetted parts.
- (30) Design and manufacturing according to ASME B31.1. No code stamp or ASME certificate available. Welding in accordance with ASME IX.
- (31) Only available with Material of construction code 1, Operating temperature and pressure code S, H, or P, Probe type 3A, 3B, 3V, 4U, 4A, 4B, 4S, 5A, or 5B, together with ASME flanges size 2-in, 3-in, or 4-in.
- (32) Only available with Signal output code H and Probe type code 3V or 4U.
- (33) Suitable for use as a level sensor part of a limiting device, in accordance with EN 12952-11 and EN 12953-9.
- (34) For Probe Type 3A, 3B, 3C, 4A, 4B, 4S, and PTFE-coated 5A.
- (35) Transmitters with aluminum housing are not approved for open deck installations.
- (36) Not available with PTFE covered probes.
- (37) Requires Remote housing code B3, and Probe type code 3V or 4U.
- (38) Only available for end-destination countries within the EAC Economic Union (Russia, Belarus, Kazakhstan, Armenia, and Kyrgyzstan).
- (39) Consider any temperature limitations dependent on Material of construction, Hazardous locations certifications, and/or O-ring selection.
- (40) Not available with option code QS or U1.
- (41) For ambient temperatures between -67 °F (-55 °C) and -40 °F (-40 °C), the ambient temperature effect is ± 0.012 in. (0.3 mm) /°K or ± 45 ppm/°K of measured value, whichever is greatest. Other performance specifications apply to ambient temperatures between -40 °F (-40 °C) and 185 °F (85 °C).
- (42) Only available with HART 4-20 mA output (code H), standard operating temperature and pressure (code S), material of construction (code 1), and flexible single lead probes (probe type 5A or 5B).
- (43) Rosemount extended warranties have a limited warranty of three or five years from date of shipment.
- (44) Available for SST, Alloy C-276, Alloy 400, Alloy 825, and Duplex 2205 probes, type 2A, 4A, 4B, 4S, and 5A. Same disc material as probe material. For more information, see [Centering disc for pipe installations](#).
- (45) Available for probe types 2A, 4A, 4B, 4S, and 5A. Not available with Operating Temperature and Pressure code H or Material of Construction codes 7 and 8.
- (46) Not available with Marine / shipboard approvals.
- (47) Selecting the XC option code on the Rosemount 5300 Guided Wave Radar and a Rosemount chamber will result in matching, consolidating, configuring, and shipping of the two products in one crate. Note that the flange bolts are only hand-tightened. Long rigid single lead probes (>8 ft./2.5 m) are ship separately in order to reduce transportation risk damage.

Rosemount 5303 Level for Solids

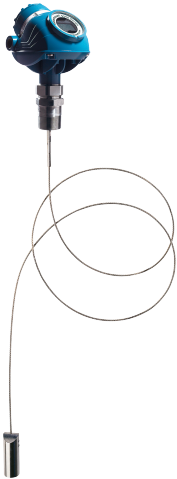

Rosemount 5303 Guided Wave Radar Level Transmitter provides industry leading measurement capabilities and reliability on solids. Characteristics include:

- Direct Switch Technology and Probe End Projection to handle low reflective media and long measuring ranges
- Measurement independent of dust, moisture and material fluctuations
- HART 4-20 mA, FOUNDATION™ Fieldbus, Modbus, or IEC 62591 (*WirelessHART®*) with the THUM Adapter (see [Emerson Wireless 775 THUM™ Adapter](#) for details)
- Probes for high physical weight loads (probe type 6A and 6B)
- Long stud available to prevent contact with nozzle (LS option)

Specification and selection of product materials, options, or components must be made by the purchaser of the equipment. See [Material selection](#) for more information on material selection.

CONFIGURE >
VIEW PRODUCT >

Table 2: Rosemount 5303 Level for Solids Ordering Information

The starred options (★) represent the most common options and should be selected for best delivery. The non-starred offerings are subject to additional delivery lead time.

Model	Product description	
5303	Guided Wave Solids Level Transmitter	★
Signal output		
H	4-20 mA with HART communication (default output from factory is HART 5, add option code HR7 for HART 7) (see 4-20 mA HART® (output option code H) for details)	★
F	FOUNDATION Fieldbus (see FOUNDATION™ Fieldbus (output option code F) for details)	★
M	RS-485 with Modbus communication (see Modbus® (output option code M) for details)	★
Housing material		
A	Polyurethane-covered Aluminum (Aluminum alloy A360, maximum 0.6 percent Cu)	★
S	Stainless Steel, Grade CF8M (ASTM A743)	
Conduit / cable threads		Note
1	½ - 14 NPT	1 plug included
2	M20 x 1.5 adapter	1 adapter and 1 plug included
4	2 pcs M20 x 1.5 adapter	2 adapters and 1 plug included
G ⁽¹⁾⁽²⁾	Metal cable gland (½ - 14 NPT)	2 glands and 1 plug included
E ⁽³⁾	M12, 4-pin, Male connector (eurofast)	1 plug included
M ⁽³⁾	A size Mini, 4-pin, Male connector (minifast)	1 plug included

Table 2: Rosemount 5303 Level for Solids Ordering Information (continued)

Operating temperature and pressure (see Process temperature and pressure rating) ⁽⁴⁾			Probe type	
Standard (Std)				
S	Design and operating temperature: -40 to 302 °F (-40 to 150 °C)	Design and operating pressure: -15 to 580 psig (-1 to 40 bar)	All	★
Material of construction ⁽⁵⁾ : process connection / probe			Probe type	
1	316/316L/ EN 1.4404		All	★
Sealing, O-ring material (consult factory for other O-ring materials)				
V	Viton® Fluoroelastomer			★
E	Ethylene Propylene (EPDM)			★
K	Kalrez® 6375 Perfluoroelastomer			★
B	Nitrile Butadiene (NBR)			★
Probe type		Process connection	Probe lengths	
5A ⁽⁶⁾	Flexible Single Lead with weight, 4 mm	Flange / 1-in., 1½-in., 2-in. Thread	Min: 3 ft. 4 in. (1 m) Max: 115 ft. (35 m)	★
5B ⁽⁷⁾	Flexible Single Lead with chuck, 4 mm	Flange / 1-in., 1½-in., 2-in. Thread	Min: 3 ft. 4 in. (1 m) Max: 115 ft. (35 m)	★
6A ⁽⁸⁾	Flexible Single Lead with weight, 6 mm	Flange / 1-in., 1½-in., 2-in. Thread	Min: 3 ft. 4 in. (1 m) Max: 164 ft. (50 m)	★
6B ⁽⁸⁾	Flexible Single Lead with chuck, 6 mm	Flange / 1-in., 1½-in., 2-in. Thread	Min: 3 ft. 4 in. (1 m) Max: 164 ft. (50 m)	★
Probe length units				
E	English (feet, in.)			★
M	Metric (meters, centimeters)			★
Total probe length (feet/m) ⁽⁹⁾				
XXX	0-164 ft. or 0-50 m			★
Total probe length (in./cm) ⁽⁹⁾				
XX	0-11 in. or 0-99 cm			★
Process connection - size / type (consult the factory for other process connections)				
ASME flanges ⁽¹⁰⁾⁽¹¹⁾				
AA	2 in. Class 150, RF (Raised Face Type)			★
AB	2 in. Class 300, RF (Raised Face Type)			★
BA	3 in. Class 150, RF (Raised Face Type)			★
BB	3 in. Class 300, RF (Raised Face Type)			★
CA	4 in. Class 150, RF (Raised Face Type)			★
CB	4 in. Class 300, RF (Raised Face Type)			★
DA	6 in. Class 150, RF (Raised Face Type)			

Table 2: Rosemount 5303 Level for Solids Ordering Information (continued)

EN 1092-1 flanges ⁽¹²⁾		
HB	DN50, PN40, Type A flat face	★
IA	DN80, PN16, Type A flat face	★
IB	DN80, PN40, Type A flat face	★
JA	DN100, PN16, Type A flat face	★
JB	DN100, PN40, Type A flat face	★
HI	DN50, PN40, Type E spigot face	
HP	DN50, PN16, Type C tongue face	
HQ	DN50, PN40, Type C tongue face	
IH	DN80, PN16, Type E spigot face	
II	DN80, PN40, Type E spigot face	
IP	DN80, PN16, Type C tongue face	
IQ	DN80, PN40, Type C tongue face	
JH	DN100, PN16, Type E spigot face	
JI	DN100, PN40, Type E spigot face	
JP	DN100, PN16, Type C tongue face	
JQ	DN100, PN40, Type C tongue face	
KA	DN150, PN16, Type A flat face	
JIS flanges ⁽¹²⁾		
UA	50A, 10K, RF (Raised Face Type)	★
VA	80A, 10K, RF (Raised Face Type)	★
XA	100A, 10K, RF (Raised Face Type)	★
UB	50A, 20K, RF (Raised Face Type)	
VB	80A, 20K, RF (Raised Face Type)	
XB	100A, 20K, RF (Raised Face Type)	
YA	150A, 10K, RF (Raised Face Type)	
YB	150A, 20K, RF (Raised Face Type)	
ZA	200A, 10K, RF (Raised Face Type)	
ZB	200A, 20K, RF (Raised Face Type)	
Threaded connections ⁽¹¹⁾		Probe type
RA	1½-in. NPT thread	All
RC	2-in. NPT thread	All
RB	1-in. NPT thread	All
SA	1½-in. BSP (G 1½-in.) thread	All
SB	1-in. BSP (G 1-in.) thread	All

Table 2: Rosemount 5303 Level for Solids Ordering Information (continued)

Hazardous locations certifications (see Product certifications)		
NA	No Hazardous Locations Certifications	★
E1 ⁽¹³⁾	ATEX Flameproof	★
E3 ⁽¹³⁾	China Flameproof	★
E5 ⁽¹³⁾	USA Explosion-proof	★
E6 ⁽¹³⁾	Canadian Explosion-proof	★
E7 ⁽¹³⁾	IECEX Flameproof	★
I1	ATEX Intrinsic Safety	★
IA ⁽¹⁴⁾	ATEX FISCO Intrinsic Safety	★
I3	China Intrinsic Safety	★
IC ⁽¹⁴⁾	China FISCO Intrinsic Safety	★
I5	USA Intrinsic Safety and Non-Incendive	★
IE ⁽¹⁴⁾	USA FISCO Intrinsic Safety	★
I6	Canadian Intrinsic Safety	★
IF ⁽¹⁴⁾	Canadian FISCO Intrinsic Safety	★
I7	IECEX Intrinsic Safety	★
IG ⁽¹⁴⁾	IECEX FISCO Intrinsic Safety	★
E2 ⁽¹³⁾	INMETRO Flameproof	
EM ⁽¹³⁾	Technical Regulations Customs Union (EAC) Flameproof	
I2	INMETRO Intrinsic Safety	
IB ⁽¹⁴⁾	INMETRO FISCO Intrinsic Safety	
IM	Technical Regulations Customs Union (EAC) Intrinsic Safety	
IN ⁽¹⁴⁾	Technical Regulations Customs Union (EAC) FISCO Intrinsic Safety	
E4 ⁽¹³⁾	Japan Flameproof	
EP ⁽¹³⁾ ⁽¹⁵⁾	Republic of Korea Flameproof	
KA ⁽¹³⁾	ATEX, USA, Canadian Flameproof/Explosion-proof	
KB ⁽¹³⁾	ATEX, USA, IECEX Flameproof/Explosion-proof	
KC ⁽¹³⁾	ATEX, Canadian, IECEX Flameproof/Explosion-proof	
KD ⁽¹³⁾	USA, Canadian, IECEX Flameproof/Explosion-proof	
KE	ATEX, USA, Canadian Intrinsic Safety	
KF	ATEX, USA, IECEX Intrinsic Safety	
KG	ATEX, Canadian, IECEX Intrinsic Safety	
KH	USA, Canadian, IECEX Intrinsic Safety	
KI ⁽¹⁴⁾	FISCO - ATEX, USA, Canadian Intrinsic Safety	
KJ ⁽¹⁴⁾	FISCO - ATEX, USA, IECEX Intrinsic Safety	
KK ⁽¹⁴⁾	FISCO - ATEX, Canadian, IECEX Intrinsic Safety	

Table 2: Rosemount 5303 Level for Solids Ordering Information (continued)

KL ⁽¹⁴⁾	FISCO - USA, Canadian, IECEx Intrinsic Safety	
N1	ATEX Type n	
N7	IECEX Type n	
Options (include with selected model number)		
Display		
M1	Integral digital display	★
Communication		
HR7	4–20 mA with digital signal based on HART 7 protocol	★
Hydrostatic testing		
P1 ⁽¹⁶⁾	Hydrostatic testing	★
Factory configuration		
C1	Factory configuration (Configuration Data Sheet required with order, available at Emerson.com/Rosemount)	★
Alarm limit configuration		
C4	Namur alarm and saturation levels, high alarm	★
C5	Namur alarm and saturation levels, low alarm	★
C8	Low alarm ⁽¹⁷⁾ (standard Rosemount alarm and saturation levels)	★
Welding documentation⁽¹⁸⁾		
Q66	Welding Procedure Qualification Record Documentation	★
Q67	Welder Performance Qualification Record	★
Q68	Welding Procedure Specification	★
Safety certifications		
QS	Prior-use certificate of FMEDA Data. Only available with HART 4-20 mA output (output code H).	★
QT	Safety-certified to IEC 61508 with certificate of FMEDA data. Only available with HART 4-20 mA output (output code H).	★
Special certifications		
Q4	Calibration Data Certification	★
Q8 ⁽¹⁹⁾	Material Traceability Certification consistent with ISO10474-3.1:2013 / EN10204-3.1:2004	★
QG	Calibration Certificate and GOST Verification Certificate (only for end-destination country Russia)	
Dye penetration test certificate		
Q73	Certificate of Liquid Penetrant Inspection	★
Positive material identification certificate		
Q76	Positive Material Identification Certificate of Conformance	★
Installation options		
LS	Long stud 9.8 in (250 mm) for flexible single lead probe to prevent contact with wall/nozzle. Standard stud length is 3.9 in (100 mm) for probes 5A and 5B; 5.9 in. (150 mm) for probes 6A and 6B	★

Table 2: Rosemount 5303 Level for Solids Ordering Information (continued)

BR	316L Mounting Bracket for 1½-in. NPT Process Connection (RA) (see Figure 48)	
Transient protection		
T1	Transient Protection Terminal Block. Selectable with HART 4-20 mA output (output code H). Already included in all FOUNDATION Fieldbus variations.	★
Diagnostic functionality		
D01	FOUNDATION Fieldbus Diagnostics Suite (includes Signal Quality Metrics diagnostics)	★
DA1	HART Diagnostics Suite (includes Signal Quality Metrics diagnostics)	★
Overfill prevention		
U1	WHG Overfill Approval	★
Extended product warranty		
WR3 ⁽²⁰⁾	3-year limited warranty	★
WR5 ⁽²⁰⁾	5-year limited warranty	★
Remote housing mounting (see Figure 49)		
B1	1m / 3.2 ft. Remote Housing Mounting Cable and 316L Bracket	
B2	2m / 6.5 ft. Remote Housing Mounting Cable and 316L Bracket	
B3	3m / 9.8 ft. Remote Housing Mounting Cable and 316L Bracket	
Engineered solutions (see Engineered solutions)		
Rxxxx	Engineered Solutions beyond standard model codes. (Consult factory for details)	
Example model string: 5303-H-A-1-S-1-V-6A-M-025-50-AA-I1-M1C1.		
E-025-05, means 25 ft. and 5 in. probe length. M-025-50, means 25.5 m.		

- (1) Not available with explosion-proof or flameproof approvals.
- (2) Minimum temperature is -20 °C (-4 °F).
- (3) Not available with explosion-proof, flameproof, or type n approvals.
- (4) Process seal rating. Final rating depends on Material of construction, Flange and O-ring selection. See “Temperature and pressure limits” on [Process temperature and pressure rating, Flange rating, Tri Clamp rating, and Plate design](#).
- (5) For other materials, consult the factory.
- (6) 0.79 lb (0.36 kg) standard weight for flexible single lead probe. L=5.5 in. (140 mm).
- (7) Extra length for fastening is added in the factory.
- (8) 1.2 lb (0.56 kg) standard weight for flexible single lead probe. L=5.5 in. (140 mm).
- (9) Probe weight included if applicable. Give the total probe length in feet and inches or meters and centimeters, depending on selected probe length unit. If tank height is unknown, please round up to an even length when ordering. Probes can be cut to exact length in field. Maximum allowable length is determined by process conditions. See [Total probe length](#) for more probe length guidance.
- (10) Design according to ASME B31.1. No code stamp or ASME certificate available.
- (11) Available in 316L. For other materials, consult the factory.
- (12) Available in 316L and EN 1.4404. For other materials consult the factory.
- (13) Probes are intrinsically safe.
- (14) Requires FOUNDATION Fieldbus signal output (U_i parameter listed in [Product certifications](#)).
- (15) The EP (Republic of Korea Flameproof) certificate is based on the E7 (IECEx Flameproof) certificate, therefore model code E7 is stated in the certificate instead of EP.
- (16) Available for tank connection with flange.
- (17) The standard alarm setting is high.
- (18) Weldings in accordance with EN/ISO standards.
- (19) Certificate includes all pressure retaining wetted parts.
- (20) Rosemount extended warranties have a limited warranty of three or five years from date of shipment.

Accessories

Table 3: Accessories Ordering Information

The starred options (★) represent the most common options and should be selected for best delivery. The non-starred offerings are subject to additional delivery lead time.

Weight kit			
03300-7001-0002	Weight kit flexible twin lead		
03300-7001-0003	Weight kit flexible 4 mm single lead		
03300-7001-0004	Weight kit flexible 6 mm single lead		
Centering discs for rigid single lead probe (d=0.3 in./8 mm)⁽¹⁾⁽²⁾		Outer diameter	
03300-1655-0001	Kit, 2-in. Centering disc, SST	1.8 in. (45 mm)	★
03300-1655-0006	Kit, 2-in. Centering disc, PTFE	1.8 in. (45 mm)	★
03300-1655-0002	Kit, 3-in. Centering disc, SST	2.7 in. (68 mm)	★
03300-1655-0007	Kit, 3-in. Centering disc, PTFE	2.7 in. (68 mm)	★
03300-1655-0003	Kit, 4-in. Centering disc, SST	3.6 in. (92 mm)	★
03300-1655-0008	Kit, 4-in. Centering disc, PTFE	3.6 in. (92 mm)	★
03300-1655-0004	Kit, 6-in. Centering disc, SST	5.55 in. (141 mm)	
03300-1655-0009	Kit, 6-in. Centering disc, PTFE	5.55 in. (141 mm)	
03300-1655-0005	Kit, 8-in. Centering disc, SST	7.40 in. (188 mm)	
03300-1655-0010	Kit, 8-in. Centering disc, PTFE	7.40 in. (188 mm)	
Centering discs for rigid single lead probe (d=0.5 in./13 mm)⁽¹⁾⁽²⁾		Outer diameter	
03300-1655-0301	Kit, 2-in. Centering disc, SST	1.8 in. (45 mm)	★
03300-1655-0306	Kit, 2-in. Centering disc, PTFE	1.8 in. (45 mm)	★
03300-1655-0302	Kit, 3-in. Centering disc, SST	2.7 in. (68 mm)	★
03300-1655-0307	Kit, 3-in. Centering disc, PTFE	2.7 in. (68 mm)	★
03300-1655-0303	Kit, 4-in. Centering disc, SST	3.6 in. (92 mm)	★
03300-1655-0308	Kit, 4-in. Centering disc, PTFE	3.6 in. (92 mm)	★
03300-1655-0304	Kit, 6-in. Centering disc, SST	5.55 in. (141 mm)	
03300-1655-0309	Kit, 6-in. Centering disc, PTFE	5.55 in. (141 mm)	
03300-1655-0305	Kit, 8-in. Centering disc, SST	7.40 in. (188 mm)	
03300-1655-0310	Kit, 8-in. Centering disc, PTFE	7.40 in. (188 mm)	
Centering discs for flexible single/twin lead probes⁽¹⁾⁽²⁾		Outer diameter	
03300-1655-1001	Kit, 2-in. Centering disc, SST	1.8 in. (45 mm)	★
03300-1655-1006	Kit, 2-in. Centering disc, PTFE	1.8 in. (45 mm)	★
03300-1655-1002	Kit, 3-in. Centering disc, SST	2.7 in. (68 mm)	★
03300-1655-1007	Kit, 3-in. Centering disc, PTFE	2.7 in. (68 mm)	★
03300-1655-1003	Kit, 4-in. Centering disc, SST	3.6 in. (92 mm)	★
03300-1655-1008	Kit, 4-in. Centering disc, PTFE	3.6 in. (92 mm)	★

Table 3: Accessories Ordering Information (continued)

03300-1655-1004	Kit, 6-in. Centering disc, SST	5.55 in. (141 mm)	
03300-1655-1009	Kit, 6-in. Centering disc, PTFE	5.55 in. (141 mm)	
03300-1655-1005	Kit, 8-in. Centering disc, SST,	7.40 in. (188 mm)	
03300-1655-1010	Kit, 8-in. Centering disc, PTFE	7.40 in. (188 mm)	
Centering discs for mounting between segments (probe type 4S only)		Outer diameter	
03300-1656-1002	2-in. Centering disc (1 pc), PTFE, Segmented rigid single lead	1.8 in. (45 mm)	
03300-1656-1003	3-in. Centering disc (1 pc), PTFE, Segmented rigid single lead	2.7 in. (68 mm)	
03300-1656-1004	4-in. Centering disc (1 pc), PTFE, Segmented rigid single lead	3.6 in. (92 mm)	
03300-1656-1006	6-in. Centering disc (1 pc), PTFE, Segmented rigid single lead	5.55 in. (141 mm)	
03300-1656-1008	8-in. Centering disc (1 pc), PTFE, Segmented rigid single lead	7.40 in. (188 mm)	
03300-1656-3002	2-in. Centering disc (3 pcs), PTFE, Segmented rigid single lead	1.8 in. (45 mm)	
03300-1656-3003	3-in. Centering disc (3 pcs), PTFE, Segmented rigid single lead	2.7 in. (68 mm)	
03300-1656-3004	4-in. Centering disc (3 pcs), PTFE, Segmented rigid single lead	3.6 in. (92 mm)	
03300-1656-3006	6-in. Centering disc (3 pcs), PTFE, Segmented rigid single lead	5.55 in. (141 mm)	
03300-1656-3008	8-in. Centering disc (3 pcs), PTFE, Segmented rigid single lead	7.40 in. (188 mm)	
03300-1656-5002	2-in. Centering disc (5 pcs), PTFE, Segmented rigid single lead	1.8 in. (45 mm)	
03300-1656-5003	3-in. Centering disc (5 pcs), PTFE, Segmented rigid single lead	2.7 in. (68 mm)	
03300-1656-5004	4-in. Centering disc (5 pcs), PTFE, Segmented rigid single lead	3.6 in. (92 mm)	
03300-1656-5006	6-in. Centering disc (5 pcs), PTFE, Segmented rigid single lead	5.55 in. (141 mm)	
03300-1656-5008	8-in. Centering disc (5 pcs), PTFE, Segmented rigid single lead	7.40 in. (188 mm)	
Segmented rigid single lead probe spare part kit			
03300-0050-0001	15.2 in. / 385 mm Segment for Top connection (1 pc)		
03300-0050-0002	31.5 in. / 800 mm Segment (1 pc)		
03300-0050-0003	31.5 in. / 800 mm Segment (3 pcs)		
03300-0050-0004	31.5 in. / 800 mm Segment (5 pcs)		
03300-0050-0005	31.5 in. / 800 mm Segment (12 pcs)		
Vented flanges⁽³⁾⁽⁴⁾			
03300-1812-0092	Fisher™ (249B, 259B), 316/316L		
03300-1812-0093	Fisher (249C), 316/316L		
03300-1812-0091	Masoneilan™, 316/316L		
Flushing connection rings⁽⁴⁾			
DP0002-2111-S6	2-in. ANSI, ¼-in. NPT connection, 316L		
DP0002-3111-S6	3-in. ANSI, ¼-in. NPT connection, 316L		
DP0002-4111-S6	4-in. ANSI/DN100, ¼-in. NPT connection, 316L		
DP0002-5111-S6	DN50, ¼-in. NPT connection, 316L		
DP0002-8111-S6	DN80, ¼-in. NPT connection, 316L		

Table 3: Accessories Ordering Information (continued)

HART modem and cables		
03300-7004-0001	MACTek® VIATOR® HART Modem and cables (RS232 connection)	★
03300-7004-0002	MACTek VIATOR HART Modem and cables (USB connection)	★
Remote housing mounting spare part kit		
03300-7006-0001	1 m / 3.2 ft. Remote Housing Mounting Cable and 316L Bracket	
03300-7006-0002	2 m / 6.5 ft. Remote Housing Mounting Cable and 316L Bracket	
03300-7006-0003	3 m / 9.8 ft. Remote Housing Mounting Cable and 316L Bracket	
Heat sink		
05300-7001-0002	Heat sink	
Verification reflector (high level supervision) spare part kit (requires Rosemount 5300 firmware version 2.H0 or later)		
05300-7200-0001	For 3- to 8-in. pipe/chamber (inner diameter)	
05300-7200-0002	For tanks or 10-in. pipe/chamber (inner diameter) or wider	

- (1) *If a centering disc is required for a flanged probe, the centering disc can be ordered with options Sx or Px in the model code. If a centering disc is required for a threaded connection, or as a spare part, it should be ordered using the item numbers listed in this table. Refer to [Table 35](#) for centering disc size recommendation for different pipe schedules.*
- (2) *To order a centering disc in a different material consult the factory.*
- (3) *1-½ in. NPT threaded connection (RA) is required.*
- (4) *Not available with Country certification option code J1 (CRN).*

Specifications

Performance specifications

General

Reference conditions

Single Standard probe, 77 °F (25 °C) in water (DC=80) and ambient pressure in a 4-in. pipe using Trim Near Zone function.

Reference accuracy

± 0.12 in. (3 mm) or 0.03% of measured distance, whichever is greatest

For probes with spacers, the accuracy may deviate close to the spacers. Accuracy may be affected by remote housing.

Repeatability

± 0.04 in. (1 mm)⁽¹⁾

Ambient temperature effect

± 0.008 in. (0.2 mm) /°K or ± 30 ppm/°K of measured value, whichever is greatest⁽²⁾

Electromagnetic interference effect

- Shielded cable: ± 0.2 in. (5 mm)⁽³⁾
- Unshielded cable: ± 2 in. (50 mm)⁽³⁾

For FOUNDATION™ Fieldbus units it may be required to ground the signal cable shield at the power supply and transmitter to achieve optimum performance.

Thresholds may need to be adjusted, see section “Adjusting thresholds” of the Rosemount 5300 [Reference Manual](#) for general guidelines on manual threshold settings.

Update interval

Minimum 1 update per second

Environment

Vibration resistance

- Aluminum housing: Level 1 IEC 60770-1/IEC 61298-3 ed 1 chapter 7, IACS E10
- Stainless Steel housing: IACS E10

Electromagnetic compatibility

Emission and Immunity: EMC directive 2014/30/EU, EN 61326-1:2013, and EN61326-3-1:2006.

NAMUR recommendations: NE21⁽⁴⁾

CE-mark

Complies with applicable directives (EMC, ATEX).

(1) In accordance with IEC 60770-1. See the IEC 60770-1 standard for a definition of radar specific performance parameters and if applicable corresponding test procedures.

(2) For the BR5 option code with ambient temperatures between -67 °F (-55 °C) and -40 °F (-40 °C), the ambient temperature effect is ± 0.012 in. (0.3 mm) /°K or ± 45 ppm/°K of measured value, whichever is greatest.

(3) Deviation through electromagnetic interference according to EN 61326.

(4) Namur NE21 not available with option code QT.

Built-in lightning protection

EN 61326, IEC 61000-4-5, level 2kV (6kV with T1 terminal block)

Contamination/product build-up

- Single lead probes are preferred when there is a risk of contamination (because build-up can result in the product bridging across the two leads for twin versions; between the inner lead and outer pipe for the coaxial versions).
- For viscous or sticky applications, PTFE probes are recommended. Periodic cleaning may also be required.
- For viscous or sticky applications, it is not recommended to use centering discs mounted along the single lead probe.
- Signal Quality Metrics (option code D01, or DA1) can be used to determine when to clean the probe. Transmitters equipped with the Diagnostics Suite option can calculate Signal Quality Metrics.

Table 4: Maximum Recommended Viscosity and Contamination/Build-up

Probe type	Maximum viscosity	Contamination/build-up
Single lead	8000 cP ⁽¹⁾⁽²⁾	Build-up allowed
Twin lead/Large coaxial	1500 cP	Thin build-up allowed, but no bridging
Coaxial	500 cP	Not recommended

- (1) Consult your local Emerson representative in the case of agitation/turbulence and high viscous products.
 (2) Be cautious in HTHP viscous or crystallizing media applications where temperature at instrument connection is significantly lower than process temperature with risk of coating in the upper part of probe that may reduce the measurement signal. Consider using HP or STD probes in such applications.

Measuring range

See [Table 5](#) and [Table 6](#) for each probe’s measuring range and minimum dielectric constant. Due to the measuring range depending on the application and factors described below, the values are a guideline for clean liquids. For more information, ask your local Emerson representative.

Note

For Remote Housing, see [Table 7](#) and [Table 8](#) for the maximum recommended measuring range for different remote housing lengths, installation types, dielectric constants, and probe types.

Different parameters (factors) affect the echo and therefore the maximum measuring range differs depending on application according to:

- Disturbing objects close to the probe.
- Media with higher dielectric constant (ϵ_r) gives better reflection and allows a longer measuring range.
- Surface foam and particles in the tank atmosphere may affect measuring performance.
- Heavy product build-up or contamination on the probe should be avoided since it can reduce measuring range and might cause erroneous level readings.

Table 5: Maximum Measuring Range

Probe type	Maximum measuring range
Rigid single lead/segmented rigid single lead	9 ft. 10 in. (3 m) for 8 mm probes (code 4A) 19 ft. 8 in. (6 m) for 13 mm probes (code 4B) 32 ft. 9 in. (10 m) for 13 mm probes (code 4S)
Flexible single lead	164 ft. (50 m) ⁽¹⁾
Coaxial	19 ft. 8 in. (6 m)
Large coaxial	19 ft. 8 in. (6 m)
Rigid twin lead	9 ft. 10 in. (3 m)

Table 5: Maximum Measuring Range (continued)

Probe type	Maximum measuring range
Flexible twin lead	164 ft. (50 m)

(1) Maximum measuring range for Duplex 2205 probes type 5A and 5B is 105 ft. (32 m).

Table 6: Minimum Dielectric Constant

Probe type	Minimum dielectric constant			
	Std	HP	HTHP	C
Rigid single lead/ segmented rigid single lead	1.4 ⁽¹⁾⁽²⁾ (1.25 if installed in a metallic bypass or stilling well)	1.6 ⁽¹⁾⁽²⁾ (1.4 if installed in a metallic bypass or stilling well)		
Flexible single lead	1.4, up to 49 ft. (15 m) ⁽¹⁾ 1.8, up to 82 ft. (25 m) ⁽¹⁾ 2.0, up to 115 ft. (35 m) ⁽¹⁾⁽³⁾ 3, up to 138 ft. (42 m) 4, up to 151 ft. (46 m) 6, up to 164 ft. (50 m)	1.6, up to 49 ft. (15 m) ⁽¹⁾ 1.8, up to 82 ft. (25 m) ⁽¹⁾ 2.0, up to 115 ft. (35 m) ⁽¹⁾⁽³⁾ 3, up to 138 ft. (42 m) 4, up to 151 ft. (46 m) 6, up to 164 ft. (50 m)		
Coaxial	1.2	1.4	2.0	1.4
Large coaxial	1.2	1.4	N/A	1.4
Rigid twin lead	1.4	N/A	N/A	N/A
Flexible twin lead	1.4, up to 82 ft. (25 m) ⁽¹⁾ 2.0, up to 115 ft. (35 m) ⁽¹⁾ 2.5, up to 131 ft. (40 m) ⁽¹⁾ 3.5, up to 148 ft. (45 m) 6, up to 164 ft. (50 m)	N/A	N/A	N/A

(1) Probe end projection software function will improve the minimum measurable dielectric constant. Consult the factory for details.

(2) May be lower depending on installation.

(3) Up to 49 ft. (15 m) for Duplex 2205 probes type 5A and 5B.

Table 7: Remote Housing Measuring Range for Tank Installations, ft. (m)

Probe type ⁽¹⁾	1 m remote housing			2 m remote housing			3 m remote housing		
	DC 1.4	DC 2	DC 80	DC 1.4	DC 2	DC 80	DC 1.4	DC 2	DC 80
Rigid single 8 mm	4 (1.25)	4 (1.25)	10 (3) ⁽²⁾	9 (2.75)	9 (2.75)	10 (3) ⁽²⁾	10 (3)	10 (3)	10 (3)
Rigid single 13 mm	4 (1.25)	4 (1.25)	10 (3) ⁽²⁾	9 (2.75)	9 (2.75)	10 (3) ⁽²⁾	14 (4.25)	14 (4.25)	19 (6) ⁽²⁾
Segmented rigid single	4 (1.25)	4 (1.25)	10 (3) ⁽²⁾	9 (2.75)	9 (2.75)	10 (3) ⁽²⁾	14 (4.25)	14 (4.25)	33 (10) ⁽²⁾
Flexible single	4 (1.25)	4 (1.25)	159 (48.5) ⁽²⁾	9 (2.75)	9 (2.75)	154 (47) ⁽²⁾	14 (4.25)	14 (4.25)	149 (45.5) ⁽²⁾
Coaxial/Large coaxial	19 (6)	19 (6)	19 (6)	19 (6)	19 (6)	19 (6)	19 (6)	19 (6)	19 (6)
Rigid twin	4 (1.25)	4 (1.25)	10 (3) ⁽²⁾	9 (2.75)	9 (2.75)	10 (3) ⁽²⁾	10 (3) ⁽²⁾	10 (3) ⁽²⁾	10 (3) ⁽²⁾
Flexible twin	4 (1.25)	98 (30) ⁽²⁾	159 (48.5) ⁽²⁾	9 (2.75)	98 (30) ⁽²⁾	154 (47) ⁽²⁾	14 (4.25)	98 (30) ⁽²⁾	149 (45.5) ⁽²⁾

(1) Validated for ambient temperature range -40 °F to 185 °F (-40 °C to 85 °C).

(2) Accuracy may be affected up to ± 1.2 in. (30 mm).

Table 8: Remote Housing Measuring Range for Chamber/Pipe Installations < 4 in. (100 mm), ft. (m)

Probe type ⁽¹⁾	1 m remote housing			2 m remote housing			3 m remote housing		
	DC 1.4	DC 2	DC 80	DC 1.4	DC 2	DC 80	DC 1.4	DC 2	DC 80
Rigid single 8 mm	4 (1.25)	10 (3) ⁽²⁾	10 (3)	9 (2.75)	10 (3) ⁽²⁾	10 (3)	10 (3)	10 (3)	10 (3)
Rigid single 13 mm	19 (6) ⁽²⁾	19 (6) ⁽²⁾	19 (6) ⁽²⁾	19 (6) ⁽²⁾	19 (6) ⁽²⁾	19 (6)	19 (6)	19 (6)	19 (6)
Segmented rigid single	33 (10) ⁽²⁾	33 (10) ⁽²⁾	33 (10) ⁽²⁾	33 (10) ⁽²⁾	33 (10) ⁽²⁾	33 (10)	33 (10)	33 (10)	33 (10)
Flexible single ⁽³⁾	33 (10) ⁽²⁾	33 (10) ⁽²⁾	33 (10) ⁽²⁾	33 (10) ⁽²⁾	33 (10) ⁽²⁾	33 (10) ⁽²⁾	33 (10) ⁽²⁾	33 (10) ⁽²⁾	33 (10) ⁽²⁾
Coaxial/Large coaxial	19 (6)	19 (6)	19 (6)	19 (6)	19 (6)	19 (6)	19 (6)	19 (6)	19 (6)
Rigid twin	10 (3) ⁽²⁾	10 (3) ⁽²⁾	10 (3) ⁽²⁾	10 (3) ⁽²⁾	10 (3) ⁽²⁾	10 (3) ⁽²⁾	10 (3) ⁽²⁾	10 (3) ⁽²⁾	10 (3) ⁽²⁾
Flexible twin ⁽³⁾	33 (10) ⁽²⁾	33 (10) ⁽²⁾	33 (10) ⁽²⁾	33 (10) ⁽²⁾	33 (10) ⁽²⁾	33 (10) ⁽²⁾	33 (10) ⁽²⁾	33 (10) ⁽²⁾	33 (10) ⁽²⁾

(1) Validated for ambient temperature range -40 °F to 185 °F (-40 °C to 85 °C).

(2) Accuracy may be affected up to ± 1.2 in. (30 mm).

(3) Required chamber/pipe size is 3 or 4 in. (75 - 100 mm).

Interface measuring range

The maximum allowable upper product thickness/measuring range is primarily determined by the dielectric constants of the two liquids.

Typical applications include interfaces between oil/oil-like and water/water-like liquids, with a low (<3) dielectric constant for the upper product and a high (>20) dielectric constant for the lower product. For such applications, the maximum measuring range is limited by the length of the coaxial, large coaxial, rigid twin, and rigid single lead probes.

For flexible probes, the maximum measuring range is reduced by the maximum upper product thickness, according to the diagram below. However, characteristics may vary between the different applications. Maximum distance to the interface is 164 ft. (50 m) minus the maximum upper product thickness.

Figure 2: Maximum Upper Product Thickness for the Flexible Single Lead Probe

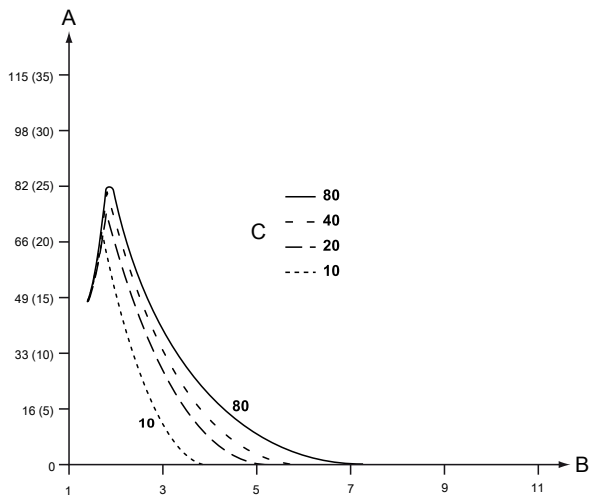

A. Maximum upper product thickness, ft. (m)

B. Upper product dielectric constant

C. Lower product dielectric constant

Figure 3: Maximum Upper Product Thickness for the Flexible Twin Lead Probe

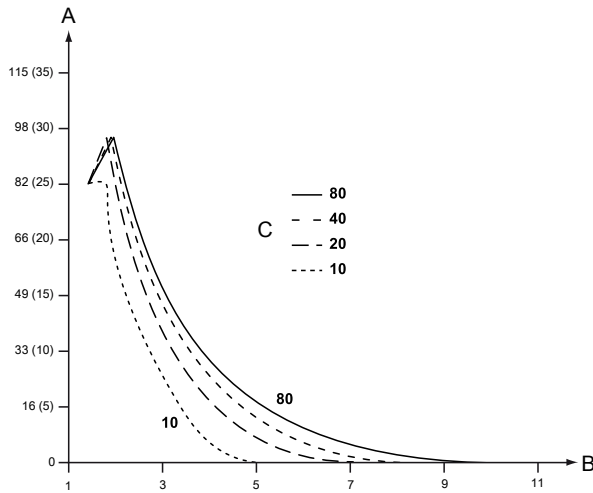

- A. Maximum upper product thickness, ft. (m)
- B. Upper product dielectric constant
- C. Lower product dielectric constant

Accuracy over measuring range

The measuring range depends on probe type, dielectric constant of the product and installation environment, and is limited by the Blind Zones at the very top and bottom of the probe. In the Blind Zones, the accuracy exceeds ± 1.18 in. (30 mm), and measurements may not be possible. Measurements close to the Blind Zones will have reduced accuracy.

The following conditions will impact the Blind Zones:

- If the single lead probes or twin probes are installed in a nozzle, the nozzle height shall be added to the specified Upper Blind Zone.
- The measuring range for the PTFE covered flexible single lead probe includes the weight when measuring on a high dielectric media.
- When using a metallic centering disc, the Lower Blind Zone is 8 in. (20 cm), including weight if applicable. When using a PTFE centering disc, the Lower Blind Zone is not affected.

Figure 4: Blind Zones

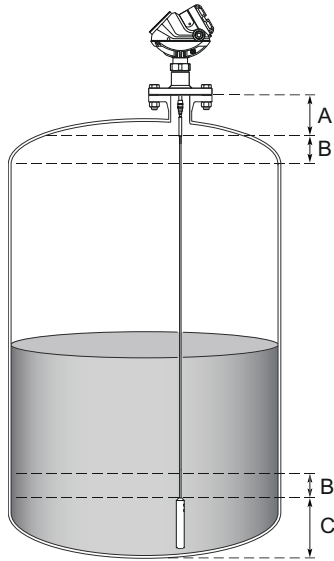

- A. Upper Blind Zone
- B. Reduced accuracy
- C. Lower Blind Zone

Note

Measurements may not be possible in the Blind Zones, and measurements close to the Blind Zones will have reduced accuracy. Therefore, the 4-20 mA points should be configured outside these zones.

Figure 5, Figure 6, Figure 7, and Figure 8 illustrate the accuracy over measuring range at reference condition with alternating probe types and varying dielectric constant of the product.

Figure 5: Accuracy Over Measuring Range for Single Lead Probes (Rigid/Segmented Rigid/Flexible)

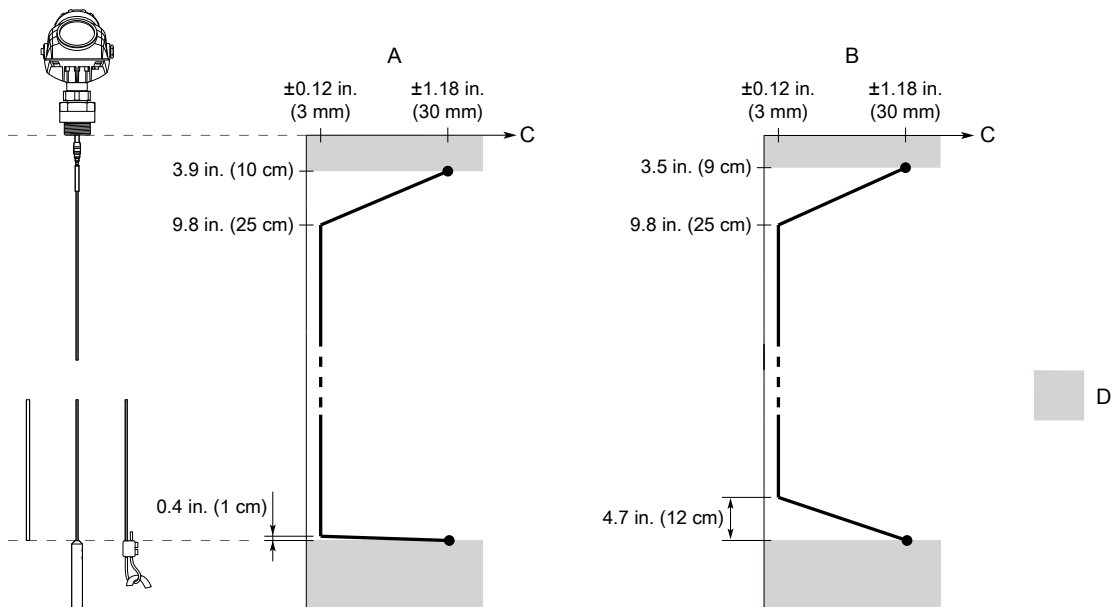

- A. Water (DC = 80)
- B. Oil (DC = 2)
- C. Accuracy
- D. Blind Zone

Figure 6: Accuracy Over Measuring Range for Twin Lead Probes

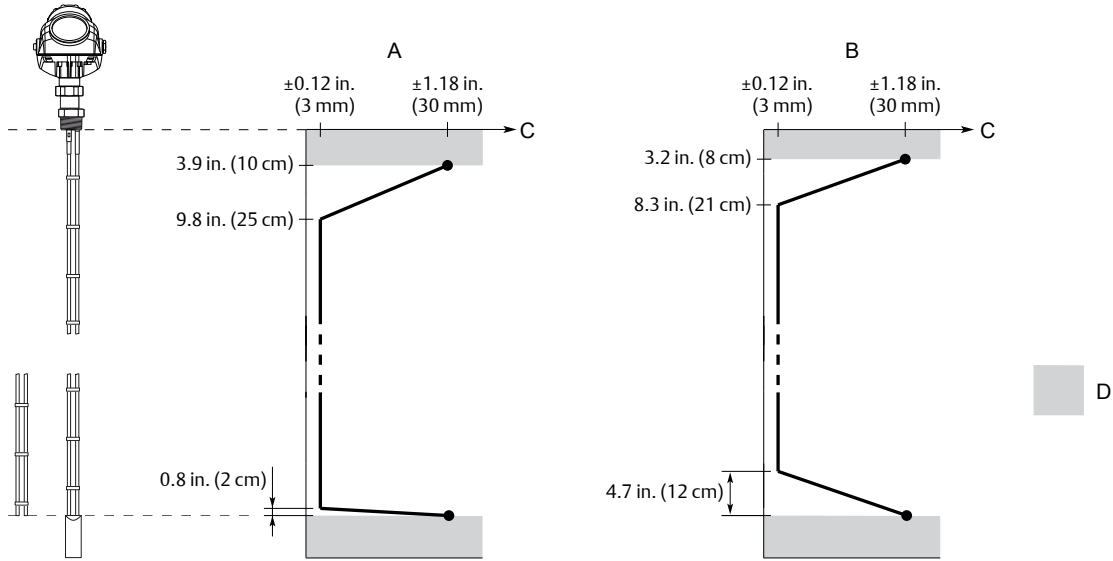

- A. Water (DC = 80)
- B. Oil (DC = 2)
- C. Accuracy
- D. Blind Zone

Figure 7: Accuracy Over Measuring Range for Coaxial Probe

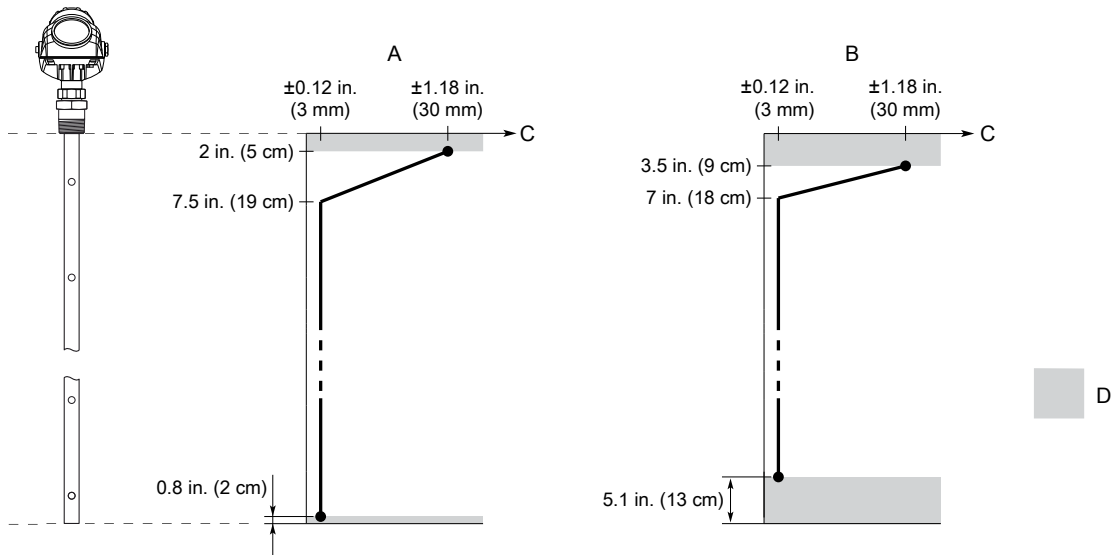

- A. Water (DC = 80)
- B. Oil (DC = 2)
- C. Accuracy
- D. Blind Zone

Figure 8: Accuracy Over Measuring Range for Large Coaxial Probe

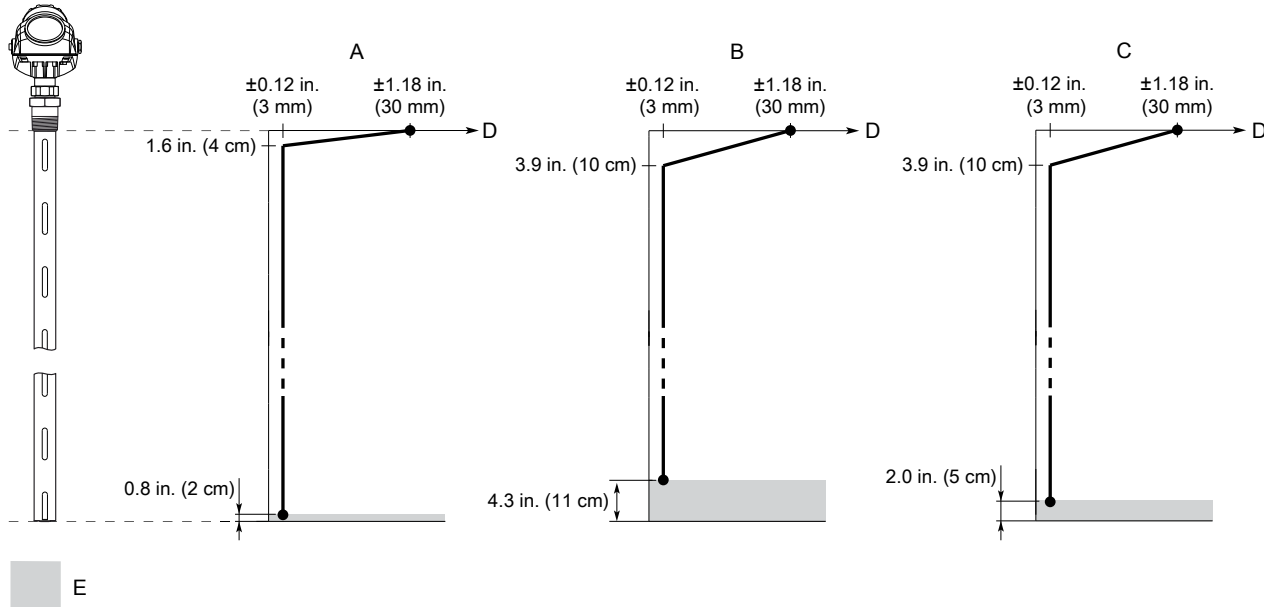

- A. Water (DC = 80)
- B. Oil (DC = 2), Liquid product level measurement mode
- C. Oil (DC = 2), Liquid product level and interface level measurement mode
- D. Accuracy
- E. Blind Zone

Functional specifications

General

Field of application

Liquids and semi-liquids level and/or liquid/liquid interfaces or solids level

- Model 5301, for liquid level or submerged interface measurements
- Model 5302, for liquid level and interface measurements
- Model 5303, for solid level measurements

Measurement principle

Time Domain Reflectometry (TDR)

Related information

[Measurement principle](#)

Microwave output power

Nominal 300 μ W, Max. 45 mW

EMC

FCC part 15 subpart B and EMC Directive (2014/30/EU). Considered to be an unintentional radiator under the Part 15 rules.

Humidity

0 to 100% relative humidity

Transmitter response time

< 8 s at damping value 2 s

The transmitter response time will be a function of the configured damping value.

Start-up time

< 40 s⁽⁵⁾

Start-up sequence

For the Rosemount™ 5300, the radar will first go to Low Alarm current for nine seconds during boot-up followed by nine seconds of High Alarm or Low Alarm current depending on alarm mode. After that measurement is re-established and the 4-20mA output settles at the actual level value.⁽⁶⁾ Refer to Figure 9 and Figure 10. If a different start-up behavior is preferred, contact your local Emerson representatives.

Figure 9: Start-Up Sequence, Alarm Mode High

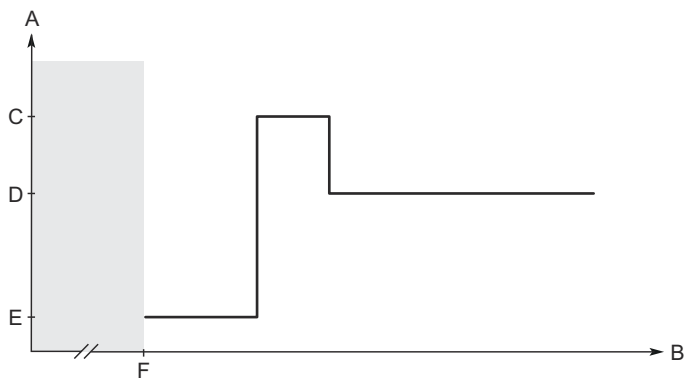

- A. Current, mA
- B. Time, s
- C. High Alarm current (Rosemount or Namur value, according to configuration)
- D. Actual level value
- E. Low Alarm current (Rosemount or Namur value, according to configuration)
- F. For option code BR5 at temperatures below -40 °F (-40 °C): Five minutes delay with an undefined current value

(5) The start-up time is extended with five additional minutes for option code BR5 at temperatures below -40 °F (-40 °C). Refer to [Start-up sequence](#).

(6) For devices with option code BR5 at temperatures below -40 °F (-40 °C), the start-up sequence is delayed for five minutes with an undefined current value.

Figure 10: Start-Up Sequence, Alarm Mode Low

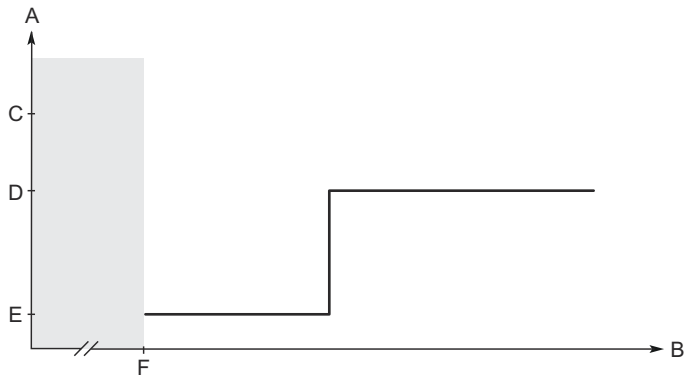

- A. Current, mA
- B. Time, s
- C. High Alarm current (Rosemount or Namur value, according to configuration)
- D. Actual level value
- E. Low Alarm current (Rosemount or Namur value, according to configuration)
- F. For option code BR5 at temperatures below -40 °F (-40 °C): Five minutes delay with an undefined current value

4-20 mA HART® (output option code H)

Output

Two-wire, 4-20 mA. Digital process variable is superimposed on 4-20 mA signal, and available to any host that conforms to the HART protocol. The digital HART® signal can be used in multidrop mode.

The default output is HART Revision 5. To order HART Revision 7 factory configured, add option code HR7. The device can also be field configured to HART Revision 7 if needed.

Signal wiring

Recommended output cabling is twisted shielded pairs, 24-12 AWG.

Rosemount 333 HART® Tri-Loop™

By sending the digital HART signal to the optional HART Tri-Loop, it is possible to have up to three additional 4–20 mA analog signals.



See the Rosemount 333 HART Tri-Loop [Product Data Sheet](#) for additional information.

Emerson Wireless 775 THUM™ Adapter

The optional Emerson Wireless 775 THUM Adapter can be mounted directly on the transmitter or by using a remote mounting kit.



IEC 62591 (WirelessHART®) enables access to multivariable data and diagnostics, and adds wireless to almost any measurement point.

See the Emerson Wireless 775 THUM Adapter [Product Data Sheet](#) and [Technical Note](#) for additional information.

Power requirements

Terminals in the transmitter housing provide connections for signal cables. The Rosemount 5300 Level Transmitter is loop-powered and operates with the following power supplies:

Table 9: External Power Supply for HART

Approval type	Input voltage (U _i) ⁽¹⁾
None	16 - 42.4 Vdc
Non-sparking/Energy Limited	16 - 42.4 Vdc
Intrinsically Safe	16 - 30 Vdc
Explosion-proof/Flameproof	20 - 42.4 Vdc

(1) Reverse polarity protection.

Figure 11: External Power Supply for HART

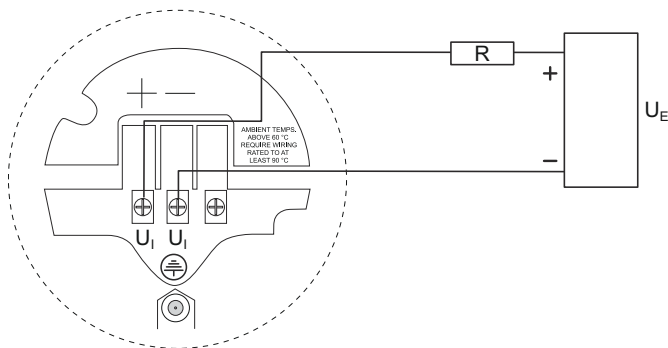

R = Load Resistance (Ω)

U_E = External Power Supply Voltage (Vdc)

U_i = Input Voltage (Vdc)

For Explosion-proof/Flameproof installations the Rosemount 5300 Level Transmitters have a built-in barrier; no external barrier needed.⁽⁷⁾

When a THUM Adapter is fitted, it adds a maximum drop of 2.5 Vdc in the connected loop.

Table 10: Minimum Input Voltage (U_i) at Different Currents

Hazardous approval	Current	
	3.75 mA	21.75 mA
	Minimum input voltage (U _i)	
Non-hazardous installations, intrinsically safe installations and Non-sparking installations	16 Vdc	11 Vdc
Explosion-proof/flameproof installations	20 Vdc	15.5 Vdc

(7) An external galvanic isolator is always recommended to be used for Flameproof/ Explosion-proof installations.

Signal on alarm

	High	Low
Standard	21.75 mA	3.75 mA
Namur NE43	22.50 mA	3.60 mA

Saturation levels

	High	Low
Standard	20.8 mA	3.9 mA
Namur NE43	20.5 mA	3.8 mA

FOUNDATION™ Fieldbus (output option code F)**Power requirements**

Terminals in the transmitter housing provide connections for signal cables. The Rosemount 5300 Level Transmitter is powered over FOUNDATION™ Fieldbus with standard fieldbus power supplies. The transmitter operates with the following power supplies:

Table 11: External Power Supply for FOUNDATION Fieldbus

Approval type	Power supply (Vdc)
None	9 - 32
Non-sparking/Energy limited	9 - 32
Intrinsically Safe	9 - 30
FISCO	9 - 17.5
Explosion-proof/flameproof	16 - 32

For Explosion-proof/Flameproof installations the Rosemount 5300 Level Transmitters have a built-in barrier; no external barrier needed.⁽⁸⁾

Quiescent current draw

22 mA

(8) An external galvanic isolator is always recommended to be used for Flameproof/ Explosion-proof installations.

Blocks and execution time

Block	Execution time
1 Resource	N/A
3 Transducer	N/A
6 Analog Input (AI)	10 ms
1 Proportional/Integrate/Derivate (PID)	15 ms
1 Signal Characterizer (SGCR)	10 ms
1 Integrator (INT)	10 ms
1 Arithmetic (ARTH)	10 ms
1 Input Selector (ISEL)	10 ms
1 Control Selector (CS)	10 ms
1 Output Splitter (OS)	10 ms

FOUNDATION Fieldbus class (basic or Link Master)

Link Master (LAS)

Number of available VCRs

Maximum 20, including one fixed

FOUNDATION Fieldbus instantiation

Yes

Conforming FOUNDATION™ Fieldbus

ITK 6.0.1

FOUNDATION Fieldbus alerts

- Field diagnostics alerts
- Plantweb™ Insight alerts

Modbus® (output option code M)**Output**

The RS-485 Modbus version communicates by Modbus RTU, Modbus ASCII, and Levelmaster protocols.

8 data bits, 1 start bit, 1 stop bit, and software selectable parity.

Baud Rate 1200, 2400, 4800, 9600 (default), and 19200 bits/s

Address Range 1 to 255 (default device address is 246)

HART communication is used for configuration via the HART terminals or tunneling via the RS-485.

External power supply

The input voltage U_i for Modbus is 8-30 Vdc (max. rating).

Wiring diagram

Figure 12: Wiring Diagram for RS-485 with Modbus®

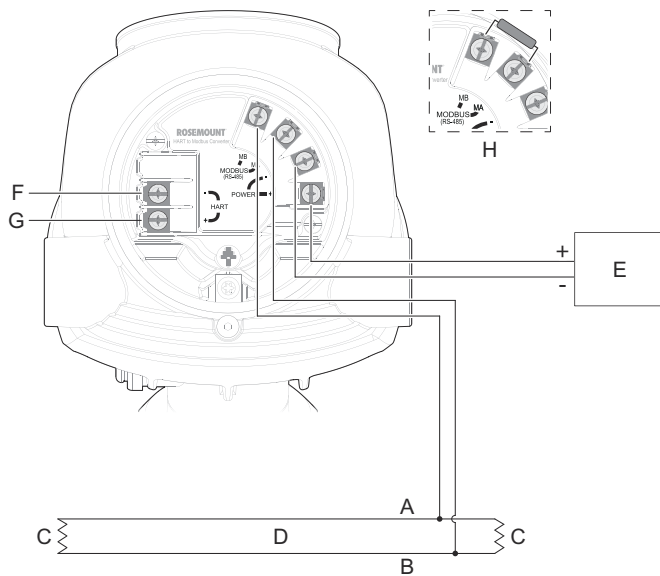

- A. "A" line
- B. "B" line
- C. 120 Ω
- D. RS-485 Bus
- E. Power supply
- F. HART -
- G. HART +
- H. If it is the last transmitter on the bus, connect the 120 Ω termination resistor.

Note

Rosemount 5300 Level Transmitters with Flameproof/Explosion-proof output have a built-in barrier; no external barrier needed.⁽⁹⁾

Power consumption

- < 0.5 W (with HART address=1)
- < 1.2 W (incl. four HART slaves)

Note

The Rosemount 5300 Level Transmitter with Modbus protocol is configured to HART address 1 at factory. This reduces power consumption by locking the analog output at 4 mA.

Display and configuration

Integral display (option code M1)

The integral digital display can toggle between: level, distance, volume, internal temperature, interface distance, interface level, peak amplitudes, interface thickness, percentage of range, analog current out.

Note

The display cannot be used for configuration purposes.

⁽⁹⁾ An external galvanic isolator is always recommended to be used for Flameproof/Explosion-proof installations.

Remote display

Data can be read remotely using the Rosemount 751 Field Signal Indicator for 4-20 mA / HART® (see [Product Data Sheet](#)), or the Rosemount 752 Remote Indicator for FOUNDATION™ Fieldbus (see [Product Data Sheet](#)).

Configuration tools

- Rosemount Radar Master (included in the delivery)
- Device Descriptor (DD) based systems, e.g. AMS Device Manager, handheld communicator, and DeltaV™
- Device Type Manager (DTM™) based systems (compliant with version 1.2 of the FDT®/DTM specification), supporting configuration in for instance Yokogawa Fieldmate/PRM, E+H FieldCare®, and PACTware™

Output units

- Level, Interface and Distance: ft., in., m, cm, or mm
- Level Rate: ft./s, m/s, in./min, m/h
- Volume: ft.³, in.³, US gals, Imp gals, barrels, yd³, m³, or liters
- Temperature: °F and °C

Output variables

Table 12: Output Variables

Variable	5301	5302	5303	PV, SV, TV, QV
Level	✓	✓	✓	✓
Distance to Level (Ullage)	✓	✓	✓	✓
Level Rate	✓	✓	✓	✓
Signal Strength	✓	✓	✓	✓
Volume	✓	✓	✓	✓
Internal Temperature	✓	✓	✓	✓
Interface Level	(✓) ⁽¹⁾	✓	N/A	✓
Interface Distance	(✓) ⁽¹⁾	✓	N/A	✓
Interface Level Rate	(✓) ⁽¹⁾	✓	N/A	✓
Interface Signal Strength	(✓) ⁽¹⁾	✓	N/A	✓
Upper Layer Thickness	(✓) ⁽¹⁾	✓	N/A	✓
Lower Volume	(✓) ⁽¹⁾	✓	N/A	✓
Upper Volume	(✓) ⁽¹⁾	✓	N/A	✓
Signal Quality	✓	✓	✓	(✓) ⁽²⁾
Surface/Noise Margin	✓	✓	✓	(✓) ⁽²⁾
Vapor DC	✓	N/A	N/A	(✓) ⁽²⁾
Analog Output Current ⁽³⁾⁽⁴⁾	✓	✓	✓	N/A
% of Range ⁽⁴⁾	✓	✓	✓	N/A

(1) Interface measurement only for fully submerged probe, see [Figure 18](#).

(2) Not available as primary variable.

(3) Not available for FOUNDATION™ Fieldbus, Modbus® Signal Output, or for HART® units in fixed current mode.

(4) LCD display variable only.

Damping

0-60 s (2 s, default value)

Diagnostics

General

Transmitter diagnostics with alerts include hardware and software errors, electronics temperature, probe missing, and invalid measurement and configuration error diagnostics. In addition to this, echo curve and variable logging including signal strength facilitate easy on-line troubleshooting.

Alerts

The transmitter is compliant with NAMUR NE 107 Field Diagnostics for standardized device diagnostic information (only available for FOUNDATION™ Fieldbus).

Diagnostics Suite (option code D01 or DA1)

Signal Quality Metrics

Diagnostics package that monitors the relations between surface, noise and threshold. The function can be used to detect abnormal conditions in the process such as probe contamination or sudden loss of signal strength. Signal Quality Metrics parameters are available as Output Variables in Rosemount Radar Master, and can be sent to Distributed Control System (DCS) to trigger an alarm.

Verification reflector (option code HL1, HL2, or HL3)

The reflector, which is available with single lead flexible probes, is used to test and continuously verify that the transmitter is functioning properly in both tank and chamber/pipe installations. Compared to traditional diagnostics that only monitor the transmitter electronics, the reflector can also be used to diagnose the upper parts of the probe inside the tank for e.g. build-up, corrosion monitoring and other process related conditions.

Figure 13: Verification Reflector

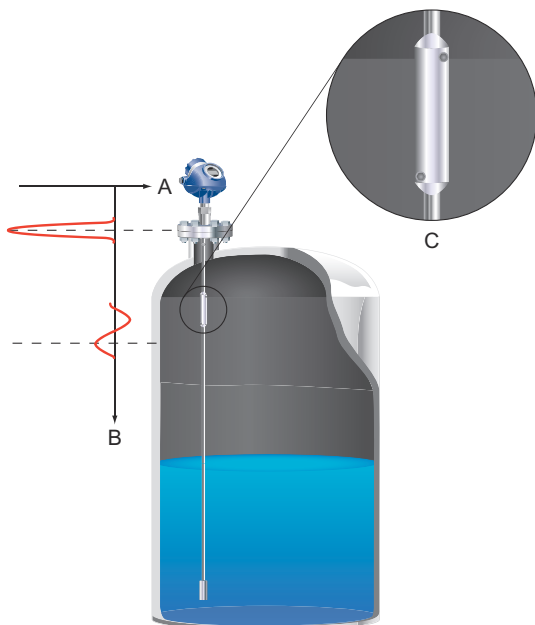

- A. Amplitude
- B. Distance
- C. Reflector

The primary use-cases for the reflector are:

- Verification of transmitter and probe (i.e. proof-testing)
- High level supervision (i.e. continuous monitoring of high level condition)

Verification

During commissioning, the location and amplitude characteristics of the reflector are stored in the transmitter. When the test procedure is later initiated, the stored reflector data is compared to the current measurement to verify the integrity of the measurement electronics and upper part of the probe.

During the test, the transmitter will output a level corresponding to the reflector position, which can be used to verify the integrity of the transmitter output.

High level supervision

Additionally, the reflector's unique echo characteristics aid the transmitter to locate a liquid surface above the reflector, thereby offering increased reliability to detect high level conditions at a user selectable limit.

The transmitter continuously monitors the status of the reflector and abnormal conditions generate alarms and alerts as appropriate.

Limitations for verification reflector

Application	Not to be used in fully submerged applications
Minimum dielectric constant	2.4 (for option code HL1) 2.0 (for option codes HL2 and HL3)

More information

For more information and installation requirements, refer to the High Level Supervision [Manual Supplement](#).

Process temperature and pressure rating

Figure 14 gives the maximum process temperature (measured at the lower part of the flange or threaded connection) and pressure rating for tank connections:

- Standard (model code S)
- HTHP - High Temperature and High Pressure (model code H)
- HP - High Pressure (model code P)
- C - Cryogenic temperature (model code C)

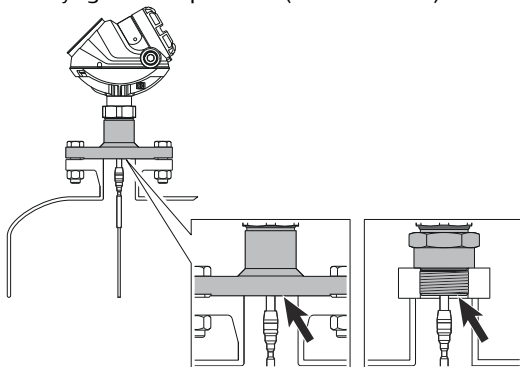

For standard tank connection, final rating may be lower depending on flange, material of construction, and O-ring selection. [Table 13](#) gives the temperature ranges for standard tank seals with different O-ring materials.

Table 13: Temperature Ranges for Standard Tank Seals with Different O-ring Material

O-ring material	Temperature °F (°C) in air	
	Minimum ⁽¹⁾	Maximum
Viton® Fluoroelastomer	5 (-15)	302 (150)
Ethylene Propylene (EPDM)	-40 (-40)	266 (130)
Kalrez® 6375 Perfluoroelastomer	14 (-10)	302 (150)
Nitrile Butadiene (NBR)	-31 (-35)	230 (110)
Low Temperature Viton Fluoroelastomer	-22 (-30)	302 (150)
Fluorosilicone (FVMQ)	-49 (-45)	302 (150)

(1) The O-ring can be stored at lower temperatures (refer to Table 14).

Note

Always check the chemical compatibility of the O-ring material with your application. If the O-ring material is not compatible with its chemical environment, the O-ring may eventually malfunction.

No wetted O-rings are used in the HTHP, HP, and C versions. Final rating may be lower depending on flange and material of construction selection.

Figure 14: Process Temperature and Pressure - Max Rating

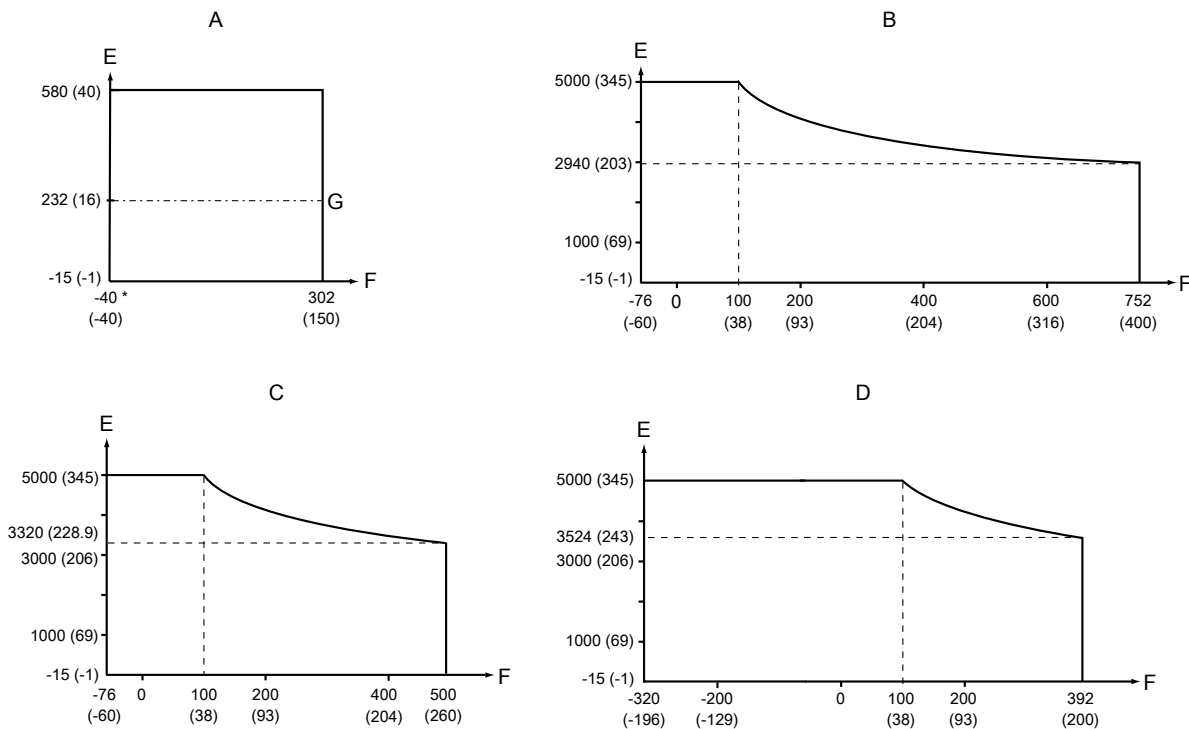

- A. Standard tank connections
- B. HTHP tank connections
- C. HP tank connections
- D. C tank connections
- E. Pressure psig (bar)
- F. Temperature °F (°C)
- G. PTFE covered probe and flange

* -49 °F (-45 °C) depending on O-ring selection.

Temperature limits

The maximum and minimum ambient temperature for the electronics depends on the process temperature (as described by Figure 15 and Figure 16) and on the approval (see Product certifications).

Figure 15: Ambient Temperature vs. Process Temperature

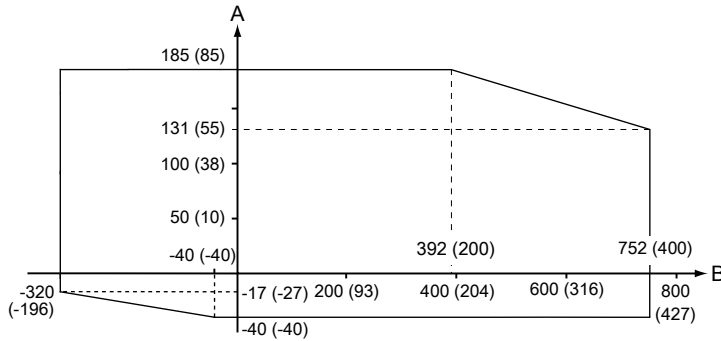

- A. Ambient temperature °F (°C)
- B. Process temperature °F (°C)

Figure 16: Ambient Temperature vs. Process Temperature with Option Code BR5

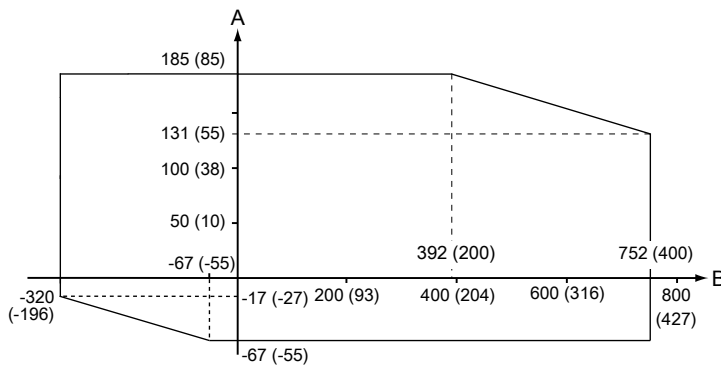

- A. Ambient temperature °F (°C)
- B. Process temperature °F (°C)

Note

Nozzle insulation for the HTHP version (Operating Temperature and Pressure code H) should not exceed 4 in. (10 cm) of height above the flange.

Note

In applications where the ambient temperature exceeds the limits of the electronics, a Remote Mounting connection can be used. The maximum temperature for the Remote Mounting connection at the vessel connection point is 302 °F (150 °C).

The heat sink installation option is required for flanges Class 1500/PN160 or higher in Dynamic Vapor Compensation applications.

Table 14: Ambient Temperature Limits

Description	Operating limit	Storage limit
Without integral display	-40 °F to 185 °F (-40 °C to 85 °C)	-58 °F to 194 °F (-50 °C to 90 °C)
With integral display	-40 °F to 158 °F (-40 °C to 70 °C) ⁽¹⁾	-40 °F to 185 °F (-40 °C to 85 °C)
Option code BR5 without integral display	-67 °F to 185 °F (-55 °C to 85 °C)	-76 °F to 194 °F (-60 °C to 90 °C)
Option code BR5 with integral display	-67 °F to 158 °F (-55 °C to 70 °C) ⁽¹⁾	-76 °F to 185 °F (-60 °C to 85 °C)

(1) Integral display may not be readable and device display updates will be slower at temperatures below -4 °F (-20 °C).

Flange rating

The flanges, except the Fisher™ and Masoneilan™ flanges, are triple certified for the materials 316, 316L, and EN 1.4404.

ASME flange rating

316 up to Class 1500 flanges according to ASME B16.5 Table 2-2.2 and 316L for Class 2500 flanges according to ASME B16.5 Table 2-2.3:

- Standard: Max. 302 °F/580 psig (150 °C/40 Bar)
- HP: Class 2500 up to max 500 °F (260 °C)
- C: Class 2500 up to max 392 °F (200 °C)
- HTHP: Class 2500 up to max 752 °F (400 °C)

Alloy C-276 (UNS N10276) according to ASME B16.5 Table 2-3.8:

- Standard: Max. 302 °F/580 psig (150 °C/40 Bar)
- HP: Class 1500 up to max 500 °F (260 °C)
- HTHP: Class 1500 up to max 752 °F (400 °C)

Alloy 825 (UNS N08825) according to ASME B16.5 Table 2-3.8:

- Standard: Max. 302 °F/580 psig (150 °C/40 Bar)
- HP: Class 1500 up to max 500 °F (260 °C)
- HTHP: Class 1500 up to max 752 °F (400 °C)

Duplex 2205 (UNS S31803) according to ASME B16.5 Table 2-2.8:

- Standard: Max. 302 °F/580 psig (150 °C/40 Bar)
- HP: Class 1500, -51 °F (-46 °C) up to max 500 °F (260 °C)
- HTHP: Class 1500, -51 °F (-46 °C) up to max 599 °F (315 °C)

EN flange rating

EN 1.4404 according to EN 1092-1 material group 13E0:

- Standard: Max. 302 °F/580 psig (150 °C/40 Bar)
- HP: PN 320 up to max 500 °F (260 °C)
- C: PN 320 up to max 392 °F (200 °C)
- HTHP: PN 320 up to max 752 °F (400 °C)

Alloy C-276 (UNS N10276) according to EN 1092-1 material group 12E0:

- Standard: Max. 302 °F/580 psig (150 °C/40 Bar)

- HP: PN 320 up to max 500 °F (260 °C)
- HTHP: PN 320 up to max 752 °F (400 °C)

Duplex 2205 (EN 1.4462) according to EN 1092-1 material group 16E0:

- Standard: Max. 580 psig (40 Bar), -22 °F (-30 °C) up to max 302 °F (150 °C)⁽¹⁰⁾
- HP: PN 320, -22 °F (-30 °C) up to max 482 °F (250 °C)⁽¹⁰⁾
- HTHP: PN 320, -22 °F (-30 °C) up to max 482 °F (250 °C)⁽¹⁰⁾

JIS flange rating

316 according to JIS B2220 material group 2.2:

- Standard: Max. 302 °F/580 psig (150 °C/40 Bar)
- HP: Max. temp. 260 °C. Final rating depends on flange.
- C: Max. temp. 200 °C. Final rating depends on flange.
- HTHP: Max. temp. 400 °C. Final rating depends on flange.

Fisher and Masoneilan flange rating

316 according to ASME B16.5 Table 2-2.2:

- Standard: Max. 302 °F/580 psig (150 °C/40 Bar)
- HP: Class 600 up to max 260 °C
- C: Class 600 up to max 200 °C
- HTHP: Class 600 up to max 400 °C

Tri Clamp rating

Tri Clamp is available for the Standard Temperature and Pressure seal.

Table 15: Tri Clamp Rating

Size	Maximum pressure (bar) ⁽¹⁾
1½-in. (37.5 mm)	16
2-in. (50 mm)	16
3-in. (75 mm)	10
4-in. (100 mm)	10

(1) The final rating depends on the clamp and gasket.

Plate design

Certain models of flanged alloy and PTFE covered probes have a tank connection design with a protective flange plate of the same material as the probe and with a backing flange in 316L/EN 1.4404. The protective flange plate prevents the backing flange from being exposed to the tank atmosphere.

(10) Minimum temperature limit due to EN13445-2.

Figure 17: Protective Plate

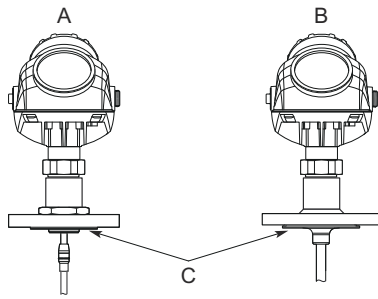

- A. Alloy probe and protective plate
- B. PTFE covered probe and protective plate
- C. Protective plate

Flange rating according to SST backing flange ASME B16.5 Table 2-2.3, EN 1092-1 material group 13E0, and JIS B2220 material group 2.3.

PTFE protective plate

- Standard: Max. 302 °F/232 psig (150 °C/16 Bar)

Alloy C-276 protective plate

- Standard: Max. 302 °F/580 psig (150 °C/40 Bar). Flange plate design is available up to Class 300/PN 40
- HP: Max. temp. 260 °C. Flange plate design is available up to Class 600/PN 63
- HTHP: Max. temp. 400 °C. Flange plate design is available up to Class 600/PN 63

Alloy 400 protective plate

- Standard: Max. 302 °F/580 psig (150 °C/40 Bar). Flange plate design is available up to Class 300/PN 40

Conditions used for flange strength calculations

See [Table 16](#) to [Table 20](#) for the conditions used for flange strength calculations.

Table 16: 316/316L Flanges

Standard	Bolting material	Gasket		Flange material	Hub material
		Standard/HP/HTHP/C	HP/HTHP/C		
ASME	Stainless steel SA193 B8M Cl.2	Soft (1a) with min. thickness 1.6 mm	Spiral wound gasket with nonmetallic filler (1b)	Stainless steel A182 Gr. F316 and EN 10222-5-1.4404	Stainless steel SA479M 316, and EN 10272-1.4404
EN, JIS	EN 1515-1/-2 group 13E0, A4-70	Soft (EN 1514-1) with min. thickness 1.6 mm	Spiral wound gasket with nonmetallic filler (EN 1514-2)		

Table 17: Process Connection with Plate Design

Standard	Bolting material	Gasket		Flange material	Hub material
		Standard/HP/HTHP/C	HP/HTHP/C		
ASME	Stainless steel SA193 B8M Cl.2	Soft (1a) with min. thickness 1.6 mm	Spiral wound gasket with nonmetallic filler (1b)	Stainless steel A182 Gr. F316L/F316 and EN 10222-5-1.4404	SB574 Gr. N10276 or SB164 Gr. N04400
EN, JIS	EN 1515-1/-2 group 13E0, A4-70	Soft (EN 1514-1) with min. thickness 1.6 mm	Spiral wound gasket with nonmetallic filler (EN 1514-2)		

Table 18: Alloy C-276 Flanges

Standard	Bolting material	Gasket		Flange material	Hub material
		Standard/HP/HTHP	HP/HTHP		
ASME	UNS N10276	Soft (1a) with min. thickness 1.6 mm	Spiral wound gasket with nonmetallic filler (1b)	SB462 Gr. N10276 (solution annealed condition) or SB575 Gr. N10276 (solution annealed condition)	SB574 Gr. N10276
EN		Soft (EN 1514-1) with min. thickness 1.6 mm	Spiral wound gasket with nonmetallic filler (EN 1514-2)		

Table 19: Alloy 825 Flanges

Standard	Bolting material	Gasket		Flange material	Hub material
		Standard/HP/HTHP	HP/HTHP		
ASME	A193 B7 or A320 L7	Soft (1a) with min. thickness 1.6 mm	Spiral wound gasket with nonmetallic filler (1b)	SB564 Gr. N08825 (solution annealed condition)	SB425 Gr. N08825 (solution annealed condition)

Table 20: Duplex 2205 Flanges

Standard	Bolting material	Gasket		Flange material	Hub material
		Standard/HTHP	HP/HTHP		
ASME	A193 B7 or A320 L7	Soft (1a) with min. thickness 1.6 mm	Spiral wound gasket with nonmetallic filler (1b)	Duplex stainless steel SA/A182 F51 and EN10222-5-1.4462	Stainless steel SA479M S31803 and EN 10272-1.4462
EN	Bumax® 88	Soft (EN 1514-1) with min. thickness 1.6 mm	Spiral wound gasket with nonmetallic filler (EN 1514-2)		

Interface measurements

The Rosemount 5302 is a good choice for measuring the interface of oil and water, or other liquids with significant dielectric differences.

It is also possible to measure interface with a Rosemount 5301 in applications where the probe is fully submerged in the liquid, using the submerged probe mode.

Rosemount 5302 with the large coaxial probe provides the ability to continuously keep track of both level and interface level in fully submerged applications. The product level and interface level mode must be selected.

Figure 18: Interface Level Measurement

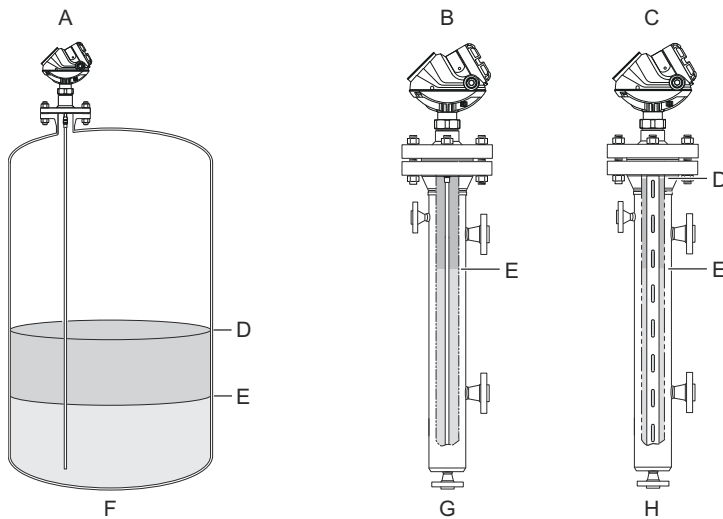

- A. Rosemount 5302
- B. Rosemount 5301
- C. Rosemount 5302 with large coaxial probe
- D. Product level
- E. Interface level
- F. Product level and interface level
- G. Interface level with submerged probe
- H. Product level and interface level with submerged probe

If interface is to be measured, follow these criteria:

- The dielectric constant of the upper product should be known and should not vary. The Rosemount Radar Master software has a built-in dielectric constant calculator to help the user estimate the upper product dielectric constant.
- The dielectric constant of the upper product must have a lower dielectric constant than the lower product to have a distinct reflection.
- The difference between the dielectric constants for the two products must be larger than 6.
- The maximum dielectric constant for the upper product is 7 for the single lead probes, 10 for the coaxial probes, and 8 for the twin lead probes.

Table 21: Minimum Detectable Upper Product Thickness

Probe type	Minimum Detectable Upper Product Thickness
Large coaxial	1 in. (2.5 cm) ⁽¹⁾
Single lead	2.4 in. (6 cm)
Twin lead	5.1 in. (13 cm)
Coaxial (standard/HP/C)	2.8 in. (7 cm)
Coaxial (HTHP)	8 in. (20 cm)

(1) Depending on application characteristics such as the upper product dielectric constant.

Sometimes there is an emulsion layer (mix of the products) between the two products which can affect interface measurements. For guidelines on emulsion situations, consult your local Emerson representative.

Related information

[Interface measuring range](#)

High pressure steam applications

Considerations

Saturated steam under high pressure can influence radar level transmitter measurements. Rosemount 5301 with Dynamic Vapor Compensation will automatically compensate for this and maintain the level accuracy.

- Probe type 3V (for 3- to 4-in. chambers) or 4U (for 2-in. chambers) must be used.
- Mount in a 2-, 3-, or 4-in. bypass chamber with flanges appropriately sized for the pressure and temperature of the application.
- Dynamic Vapor Compensation requires a minimum distance X from the flange to the surface level in order to measure the change in the vapor dielectric constant. If the level rises within this area, the unit switches over to static compensation, using the last known vapor dielectric constant.

Table 22: Minimum Distance X

Reference reflector type		Minimum distance X
Length	Option code	
Short, 14 in. (350 mm)	R1	22 in. (560 mm)
Long, 20 in. (500 mm)	R2	28 in. (710 mm)

Figure 19: Minimum Distance X and Minimum Measuring Span

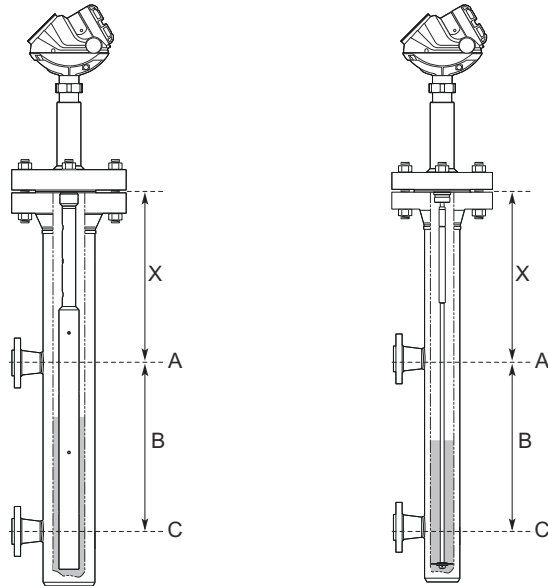

- A. Level: 100%
- B. Minimum measuring span: 12 in. (300 mm)
- C. Level: 0%

- Always ensure there are no disturbances from inlets etc. close to the reference reflector end when using probe type 4U.

Select reference reflector

- The long reflector, 20 in. (500 mm), has the best accuracy and is recommended for all chambers where the dimensions of the chamber allow for it.
- If the distance from the flange to the upper inlet is less than 28 in. (710 mm), the short reflector should be chosen. This distance is a minimum when dynamic compensation is required within the whole measuring range from the lower to the upper inlet. If this is not required, the long reflector can be used and dynamic compensation is possible up to 28 in. (710 mm) from the flange.

For more information, refer to the High Pressure Steam Applications [Technical Note](#).

Physical specifications

Material selection

Emerson provides a variety of Rosemount products with various product options and configurations including materials of construction that can be expected to perform well in a wide range of applications. The Rosemount product information presented is intended as a guide for the purchaser to make an appropriate selection for the application. It is the purchaser's sole responsibility to make a careful analysis of all process parameters (such as all chemical components, temperature, pressure, flow rate, abrasives, contaminants, etc.), when specifying product, materials, options, and components for the particular application. Emerson is not in a position to evaluate or guarantee the compatibility of the process fluid or other process parameters with the product, options, configuration or materials of construction selected.

Engineered solutions

When standard model codes are not sufficient to fulfill requirements, please consult the factory to explore possible Engineered Solutions. This is typically, but not exclusively, related to the choice of wetted materials or the design of a process connection. These Engineered Solutions are part of the expanded offerings and may be subject to additional delivery lead time. For ordering, factory will supply a special R-labeled numeric option code that should be added at the end of the standard model string.

Housing and enclosure

Type

- Dual compartment (terminal compartment and the electronics are completely separated).
- Two entries for conduit or cable connections.
- The transmitter housing is separable from probe assembly.
- The transmitter housing can be rotated in any direction.

Electrical connection

½ - 14 NPT for cable glands or conduit entries.

Optional: M20 x 1.5 conduit / cable adapter, M12 4-pin male eurofast® connector or A size Mini 4-pin male minifast® connector.

Recommended output cabling is twisted shielded pairs, 24-12 AWG.

Housing material

Polyurethane-covered Aluminum (Aluminum alloy A360, maximum 0.6 percent Cu), or Stainless Steel Grade CF8M (ASTM A743)

Ingress protection

NEMA® 4X, IP 66, IP67

Factory sealed

Yes

Weight

- Aluminum transmitter head: 4.4 lb (2 kg)
- SST transmitter head: 10.8 lb (4.9 kg)

Remote housing mounting

Kit that includes a flexible armored extension cable and a bracket for wall or pipe mounting. See [Figure 49](#) for the dimensions.

Figure 20: Remote Housing Mounting

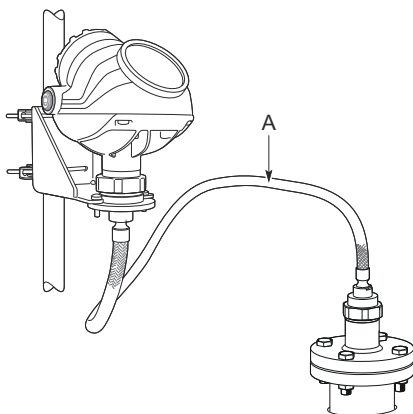

A. Remote Housing Mounting Cable: 3, 6, or 9 ft (1, 2, or 3 m)

Heat sink

The heat sink is used for remote housing mounting to keep the temperature at the vessel connection point at a maximum of 302 °F (150 °C). The heat sink installation option is available for Rosemount 5300 with Dynamic Vapor Compensation (DVC). Heat sink is mandatory for DVC probes with flanges Class 1500/PN160 or higher.

Figure 21: Heat Sink

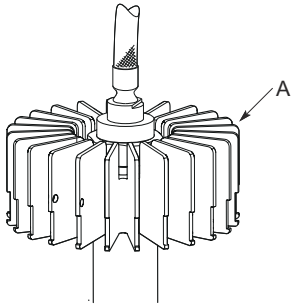

A. Heat sink

Related information

[Dimensional drawings](#)

Tank connection

The tank connection consists of a tank seal, a flange, Tri Clamp, or NPT or BSPP (G) threads.

Flange dimensions

Follows ASME B16.5, JIS B2220, and EN 1092-1 standards for blind flanges. For Proprietary Fisher™ and Masoneilan™ flanges, see [Proprietary flanges](#).

Vented flanges

Available with Masoneilan and Fisher vented flanges. Vented flanges must be ordered as accessories with a 1½-in. NPT threaded process connection (code RA); see [Proprietary flanges](#). As an alternative to a vented flange, it is possible to use a flushing connection ring on top of the standard nozzle.

Tri Clamp connection

Follows ISO 2852 standard.

Pressure Equipment Directive (PED)

Complies with 2014/68/EU article 4.3

Probes

Probe versions

Coaxial, large coaxial, rigid twin and rigid single lead, segmented rigid single lead, flexible twin and flexible single lead. Probes can be ordered in different materials and options for extreme temperatures and pressure.

For guidelines on which probe to select depending on application, see the Rosemount 5300 [Reference Manual](#).

Total probe length

This is defined from the Upper Reference Point to the end of the probe (weight included, if applicable).

Figure 22: Total Probe Length

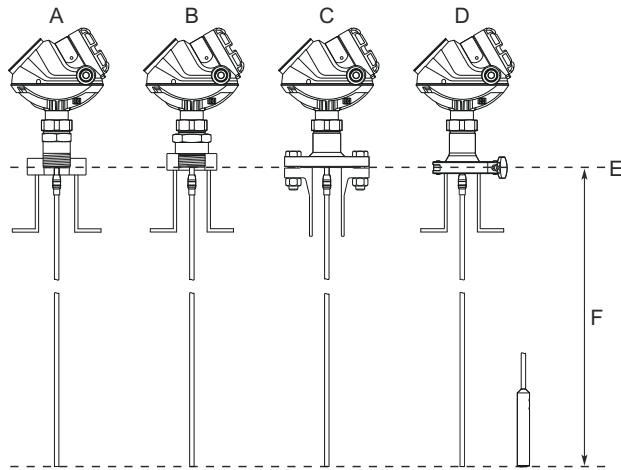

- A. NPT
- B. BSPP (G)
- C. Flange
- D. Tri Clamp
- E. Upper reference point
- F. Total probe length

Select the probe length according to the required measuring range (the probe must be hung and fully extended through the entire distance where level readings are desired).

Cut-to-fit probes

All probes can be cut in field, except for the HTHP coaxial probe and the PTFE covered probe.

However, there are some restrictions for the standard and HP/C coaxial probes: Probes over 4.1 ft. (1.25 m) can be cut up to 2 ft. (0.6 m). Shorter probes can be cut to the minimum length of 1.3 ft. (0.4 m).

Flexible single lead probes can be cut to the minimum length of 3.3 ft. (1.0 m).

Minimum and maximum probe length

Probe type	Probe length
Flexible single lead	3.3 to 164 ft. (1 to 50 m)
Rigid single lead (0.3 in./8 mm)	1.3 to 9.8 ft. (0.4 to 3 m)
Rigid single lead (0.5 in./13 mm)	1.3 to 19.7 ft. (0.4 to 6 m)
Segmented rigid single lead	1.3 to 32.8 ft. (0.4 to 10 m)
Flexible twin lead	3.3 to 164 ft. (1 to 50 m)
Rigid twin lead	1.3 to 9.8 ft. (0.4 to 3 m)
Coaxial	1.3 to 19.7 ft. (0.4 to 6 m)
Large coaxial	1.0 to 19.7 ft. (0.3 to 6 m)

Probe angle

0 to 90 degrees from vertical axis

Note

Models with QT option code should not be installed in angled probe installations.

Tensile strength

- 0.16 in. (4 mm) Flexible single lead SST: 2698 lb (12 kN)
- 0.16 in. (4 mm) Flexible single lead Alloy C-276: 1574 lb (7 kN)
- 0.16 in. (4 mm) Flexible single lead Alloy 825: 1574 lb (7 kN)
- 0.16 in. (4 mm) Flexible single lead Alloy 400: 1124 lb (5 kN)
- 0.16 in. (4 mm) Flexible single lead Duplex 2205: 1349 lb (6 kN)
- 0.24 in. (6 mm) Flexible single lead SST: 6519 lb (29 kN)
- Flexible twin lead SST: 2023 lb (9 kN)

Collapse load

- 0.16 in. (4 mm) Flexible single lead SST: 3597 lb (16 kN)
- 0.16 in. (4 mm) Flexible single lead Alloy C-276: 1798 lb (8 kN)
- 0.16 in. (4 mm) Flexible single lead Alloy 825: 1798 lb (8 kN)
- 0.16 in. (4 mm) Flexible single lead Alloy 400: 1349 lb (6 kN)
- 0.16 in. (4 mm) Flexible single lead Duplex 2205: 1574 lb (7 kN)
- 0.24 in. (6 mm) Flexible Single Lead SST: 7868 lb (35 kN)

Sideway capacity

- Rigid single lead/Segmented rigid single lead: 4.4 ft. lbf, 0.44 lb at 9.8 ft. (6 Nm, 0.2 kg at 3 m)
- Rigid twin lead: 2.2 ft. lbf, 0.22 lb at 9.8 ft. (3 Nm, 0.1 kg at 3 m)
- Coaxial/Large coaxial: 73.7 ft. lbf, 3.7 lb at 19.7 ft. (100 Nm, 1.67 kg at 6 m)

Material exposed to tank atmosphere

Table 23: Standard Probe (Operating Temperature and Pressure Code S)

Material of construction code	Material exposed to tank atmosphere
1 (probe types 6A and 6B)	316L (EN 1.4404), 316 ⁽¹⁾ , Duplex 2507 (UNS S32750/EN 1.4410), PTFE, PFA, silicone grease, and O-ring materials
1 (all other probe types)	316L (EN 1.4404), 316 ⁽¹⁾ , PTFE, PFA, silicone grease, and O-ring materials
2 and H	Alloy C-276 (UNS N10276), PTFE, PFA, silicone grease, and O-ring materials
3	Alloy 400 (UNS N04400), Alloy K500 (UNS N05500), PTFE, PFA, silicone grease, and O-ring materials
7	PTFE (1 mm PTFE cover)
8	PTFE, 316/316L (EN 1.4404), silicone grease, and O-ring materials
D	Duplex 2205 (UNS S31803/EN 1.4462), Duplex 2507 (UNS S32750/EN 1.4410), PTFE, PFA, silicone grease, and O-ring materials
E	Alloy 825 (UNS N08825), PTFE, PFA, silicone grease, and O-ring materials

(1) For flexible single/twin lead probes only.

Table 24: HTHP Probe (Operating Temperature and Pressure Code H)

Material of construction code	Material exposed to tank atmosphere
1 (probe types 3V and 4U)	316L (EN 1.4404), 316, Ceramic (Al ₂ O ₃), Graphite, and Alloy C-276 (UNS N10276)
1 (all other probe types)	316L (EN 1.4404), 316 ⁽¹⁾ , Ceramic (Al ₂ O ₃), Graphite, Alloy C-276 (UNS N10276), and Alloy 718 (UNS N07718)
2 and H	Alloy C-276 (UNS N10276), Ceramic (Al ₂ O ₃), Graphite, and Alloy 718 (UNS N07718)
D	Duplex 2205 (UNS S31803/EN 1.4462), Ceramic (Al ₂ O ₃), Graphite, Alloy C-276 (UNS N10276), and Alloy 718 (UNS N07718)
E	Alloy 825 (UNS N08825), Ceramic (Al ₂ O ₃), Graphite, Alloy C-276 (UNS N10276), and Alloy 718 (UNS N07718)

(1) For flexible single lead probes only.

Table 25: HP Probe (Operating Temperature and Pressure code P)

Material of construction code	Material exposed to tank atmosphere
1 (probe type 3C)	316L (EN 1.4404), 316, Ceramic (Al ₂ O ₃), Graphite, PTFE, and Alloy C-276 (UNS N10276)
1 (all other probe types)	316L (EN 1.4404), 316 ⁽¹⁾ , Ceramic (Al ₂ O ₃), Graphite, PFA, PTFE, Alloy C-276 (UNS N10276), and Alloy 718 (UNS N07718)
2 and H	Alloy C-276 (UNS N10276), Ceramic (Al ₂ O ₃), Graphite, PFA, PTFE, and Alloy 718 (UNS N07718)
D	Duplex 2205 (UNS S31803/EN 1.4462), Ceramic (Al ₂ O ₃), Graphite, PFA, PTFE, Alloy C-276 (UNS N10276), and Alloy 718 (UNS N07718)
E	Alloy 825 (UNS N08825), Ceramic (Al ₂ O ₃), Graphite, PFA, PTFE, Alloy C-276 (UNS N10276), and Alloy 718 (UNS N07718)

(1) For flexible single lead probes only.

Table 26: Cryogenic Probe (Operating Temperature and Pressure code C)

Material of construction code	Material exposed to tank atmosphere
1 (probe type 3C)	316L (EN 1.4404), 316, Ceramic (Al ₂ O ₃), Graphite, PTFE, and Alloy C-276 (UNS N10276)
1 (all other probe types)	316L (EN 1.4404), 316 ⁽¹⁾ , Ceramic (Al ₂ O ₃), Graphite, PFA, PTFE, Alloy C-276 (UNS N10276), and Alloy 718 (UNS N07718)

(1) For flexible single lead probes only.

Weight

Table 27: Flange and Probes

Item	Weight
Flange	Depends on flange size
Flexible single lead probe	0.05 lb/ft. (0.08 kg/m)
Rigid single lead probe (0.3-in./8 mm)	0.27 lb/ft. (0.4 kg/m)
Rigid single lead probe (0.5-in./13 mm)	0.71 lb/ft. (1.06 kg/m)
Segmented rigid single lead probe	0.71 lb/ft. (1.06 kg/m)
Flexible twin lead probe	0.09 lb/ft. (0.14 kg/m)
Rigid twin lead probe	0.40 lb/ft. (0.6 kg/m)
Coaxial probe	0.67 lb/ft. (1 kg/m)
Large coaxial probe	1.48 lb/ft. (2.2 kg/m)

Table 28: End Weight

Item	Weight
Standard weight for flexible single lead probe (0.16-in./4 mm)	0.88 lb (0.40 kg)
Short weight (W2) for flexible single lead probe (0.16-in./4 mm)	0.88 lb (0.40 kg)
Heavy weight (W3) for flexible single lead probe (0.16-in./4 mm)	2.43 lb (1.10 kg)
Weight for flexible single lead probe (0.24-in./6 mm)	1.2 lb (0.55 kg)
Weight for PTFE covered flexible single lead	2.2 lb (1 kg)
Weight for twin lead probe	1.3 lb (0.60 kg)

End weight options

A short weight is available for the single flexible probe. It is used for measuring close to the probe end and shall be used where the measuring range must be maximized. The height is 2 in. (50 mm) and the diameter is 1.5 in. (37.5 mm). The option code is W2.

Installation and mounting considerations

Free space requirement

If the probe is mounted close to a wall, nozzle or other tank obstruction, noise might appear in the level signal. Therefore the following minimum clearance, according to [Table 29](#), must be maintained.

Figure 23: Free Space Requirement

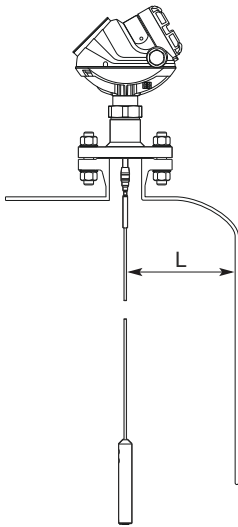

L. Clearance to tank wall

Table 29: Recommended Minimum Free Space for Optimal Performance

Probe type	Condition	Minimum clearance (L)
Rigid single lead/Segmented rigid single lead ⁽¹⁾	Smooth metal tank wall	4 in. (100 mm)
	Disturbing objects such as pipes and beams Plastic, concrete or rugged metal tank wall	16 in. (400 mm) 20 in. (500 mm) ⁽²⁾
Flexible single	Smooth metal tank wall	4 in. (100 mm)
	Disturbing objects such as pipes and beams Plastic, concrete or rugged metal tank wall	20 in. (500 mm)
Coaxial/Large coaxial ⁽¹⁾	N/A	0 in. (0 mm)
Rigid twin lead	N/A	4 in. (100 mm)
Flexible twin	N/A	4 in. (100 mm)

(1) Minimum clearance from tank bottom for the coaxial, large coaxial and rigid single probes is 0.2 in. (5 mm).

(2) Applies to measurements with DC 1.4 or lower.

Flange connection on nozzles

Figure 24: Mounting in Nozzles

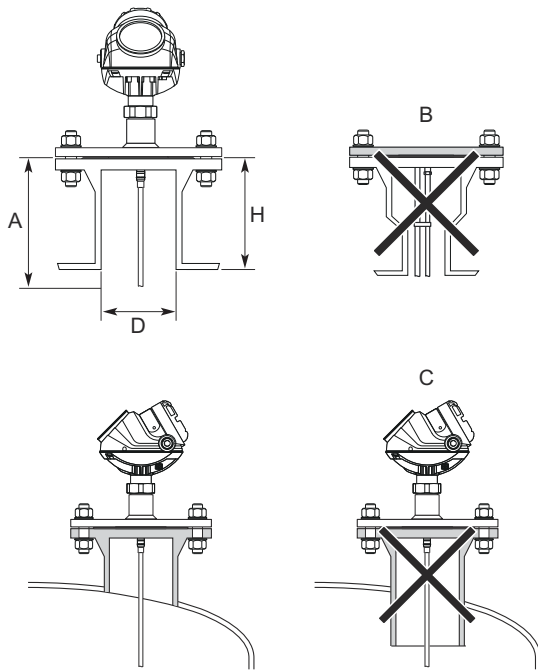

- A. Hold Off Distance/UNZ
- B. Avoid nozzles with reducer (unless using coaxial probe).
- C. Confirm the nozzle does not extend into the tank.

The transmitter can be mounted in nozzles by using an appropriate flange. It is recommended that the nozzle size is within the dimensions given in Table 30.

Table 30: Nozzle Considerations for Optimal Performance

	Single (rigid/segmented/flexible)	Coaxial/Large coaxial	Twin (rigid/flexible)
Recommended nozzle diameter (D)	6 in. (150 mm)	> probe diameter	4 in. (100 mm)
Minimum nozzle diameter (D) ⁽¹⁾	2 in. (50 mm)	> probe diameter	2 in. (50 mm)
Recommended nozzle height (H) ⁽²⁾	4 in. (100 mm) + nozzle diameter ⁽³⁾	N/A	4 in. (100 mm) + nozzle diameter

- (1) The Trim Near Zone (TNZ) function may be necessary or an Hold Off Distance/Upper Null Zone (UNZ) setup may be required to mask the nozzle.
- (2) Longer nozzles may be used in certain applications. Consult your local Emerson representative for details.
- (3) For nozzles taller than 4 in. (100 mm), the long stud version is recommended (option code LS) to prevent the flexible portion from touching the edge of the nozzle.

A long stud - 9.8 in. (250 mm) - is recommended for single flexible probes in a tall nozzle.

Figure 25: A Single Flexible Probe with a Long Stud

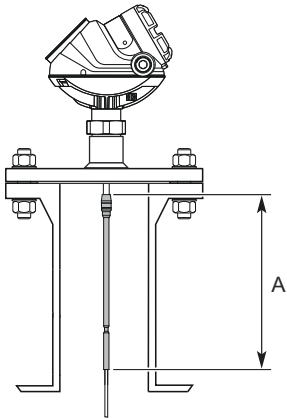

A. Long Stud (9.8 in./250 mm)

Installation in non-metallic tanks and open-air applications

Avoid major sources of electrical disturbance in proximity of the installation (e.g. electrical motors, stirrers, servo mechanisms).

Figure 26: Avoid Electromagnetic Disturbances

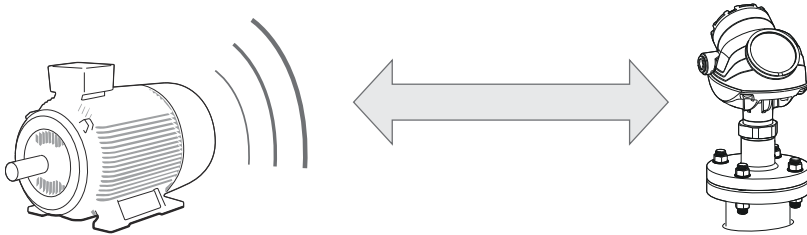

For clean liquids, use a coaxial probe to reduce effect of potential electrical disturbances.

Figure 27: Coaxial Probe in an Open-Air Application

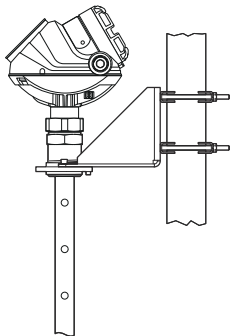

For optimal single lead probe performance in non-metallic tanks, the probe must be mounted with a metal flange, or screwed in to a metal sheet ($d > 14$ in./350 mm) if a threaded version is used.

Figure 28: Mounting in Non-Metallic Tanks

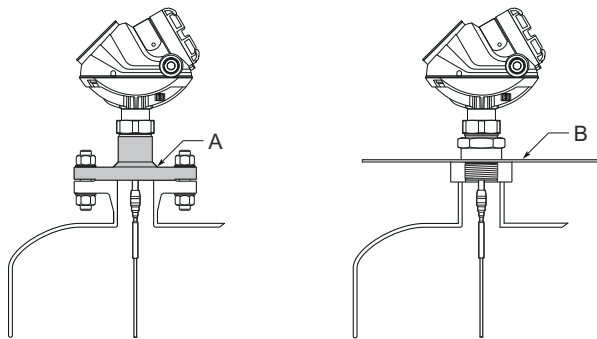

- A. Metal flange
- B. Metal sheet ($d > 14$ in./350 mm)

Minimum distance between two single probes

When installing multiple Rosemount 5300 Level Transmitters with single probes in the same tank, ensure to place the devices at proper distance from each other to avoid the risk of interference caused by cross-talk. Table 31 provides recommended minimum distance between two probes. A coaxial probe or a probe installed in a still pipe will not cause any cross-talk.

Table 31: Minimum Distance between Single Probes

Product	Minimum distance between probes
Oil (DC = 2.1)	5.2 ft. (1.6 m)
Water (DC = 80)	3.3 ft. (1.0 m)

Other mechanical considerations

To get best possible performance, the following must be considered before installing the transmitter:

- Inlets should be kept at a distance in order to avoid product filling on the probe
- Avoid physical contact between probes and agitators, as well as applications with strong fluid movement unless the probe is anchored
- Probe tie-down is recommended if the probe can move to within 1 ft. (30 cm) of any object during operations
- In order to stabilize the probe for side forces, it is possible to fix or guide the probe to the tank bottom

Figure 29: Stabilize the Probe for Side Forces

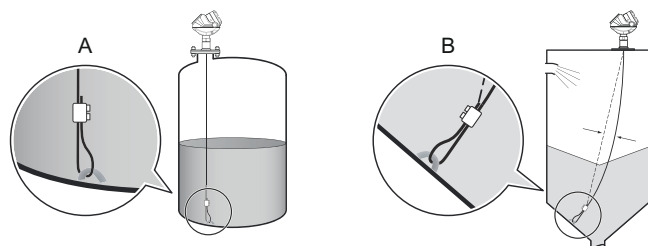

- A. Flexible single lead probe with chuck installed in liquids and in solids.
- B. For solids, it is recommended that the probe should be slack to prevent high tensile loads.

See the Rosemount 5300 Reference Manual for more mechanical installation information.

Installation in still pipe/chamber

General chamber considerations

Dimensioning the chamber/pipe correctly and selecting the appropriate probe is key to the success in these applications. When selecting a smaller chamber/pipe diameter, such as 2-in., a flexible probe is not suitable due to the chance of it coming into contact with the walls. Also, relatively large side inlets may interfere with the signal.

When gas lift and/or turbulence may occur (e.g. boiling hydrocarbons), a 3- or 4-in. chamber/pipe diameter is recommended for maximum measurement reliability. This is especially true in high pressure and high temperature installations.

Table 32: Recommended and Minimum Chamber/Still Pipe Diameters for Different Probes

Probe type	Recommended diameter	Minimum diameter
Rigid single/segmented rigid single	3 or 4 in. (75 or 100 mm)	2 in. (50 mm)
Flexible single	4 in. (100 mm)	Consult your local Emerson representative
Rigid twin ⁽¹⁾	3 or 4 in. (75 or 100 mm)	2 in. (50 mm)
Flexible twin ⁽¹⁾	4 in. (100 mm)	Consult your local Emerson representative
Coaxial	3 or 4 in. (75 or 100 mm)	1.5 in. (37.5 mm)
Large coaxial	3 or 4 in. (75 or 100 mm)	2 in. (50 mm) ⁽²⁾

(1) The center rod must be placed more than 0.6 in. (15 mm) away from the pipe wall.

(2) Applicable to pipe schedule up to 40s, 40. For higher pipe schedule consult your local Emerson representative.

Note

Metal pipes are preferred, especially in applications with low dielectric constant, to avoid disturbances from objects near the pipe.

For more information and installation requirements, refer to the Best Practices for Using Radar in Still Pipes and Chambers [Technical Note](#).

Related information

[Dimensional drawings](#)

Rosemount chamber

A Rosemount chamber allows external mounting of process level instrumentation. It supports a variety of process connections, and optional drain and vent connections. The standard Rosemount chambers are designed according to ASME B31.3. Rosemount chambers compliant with the Pressure Equipment Directive (PED) are available. Customer specific engineered solutions for Rosemount chambers are available upon request. Use option code XC to order together with the Rosemount 5300 Series Transmitters.

Use a centering disc the same diameter as the chamber if the probe length >3.3 ft. (1 m). See [Table 35](#) for which disc to use.

Existing chamber

A Rosemount 5300 Level Transmitter is the perfect replacement in an existing displacer chamber. Proprietary flanges are offered, enabling use of existing chambers to make installation easy.

Figure 30: Existing Displacer Chamber

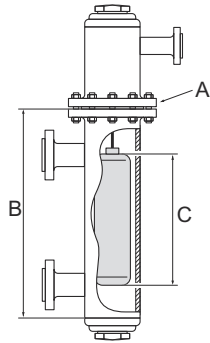

- A. Replace chamber flange
- B. Probe length
- C. Displacer length

Considerations when changing to Rosemount 5300:

- The Rosemount 5300 Level Transmitter flange choice and probe length must be correctly matched to the chamber. Both standard ASME and EN (DIN), as well as proprietary chamber flanges, are available. See [Proprietary flanges](#) to identify the proprietary flanges.
- See [Table 35](#) for guidelines on which disc size to use.
- See [Table 33](#) for guidelines on the required probe length.

Table 33: Required Probe Length in Chambers

Chamber manufacturer	Probe length ⁽¹⁾
Major torque-tube manufacture (249B, 249C, 249K, 249N, 259B)	Displacer + 9 in. (229 mm)
Masoneilan™ (torque tube operated), proprietary flange	Displacer + 8 in. (203 mm)
Other - torque tube ⁽²⁾	Displacer + 8 in. (203 mm)
Magnetrol® (spring operated) ⁽³⁾	Displacer + between 7.8 in. (195 mm) to 15 in. (383 mm)
Others - spring operated ⁽²⁾	Displacer + 19.7 in. (500 mm)

(1) If flushing ring is used, add the ring height to the probe length.
 (2) For other manufacturers, there are small variations. This is an approximate value; actual length should be verified.
 (3) Lengths vary depending on model, SG, and rating, and should be verified.

For additional information, see the Replacing Displacers with Guided Wave Radar [Technical Note](#).

Probe type in chamber considerations

When installing a Rosemount 5300 in a chamber, a large coaxial or a single lead probe is recommended. The large coaxial probe should always be considered first whenever the application and dimensions of the chamber allow for it.

Large coaxial probes are the preferred choice for installation in chambers with limited space above and below the process connections. This type of probe has the best interface resolution and outstanding performance with low dielectric fluids. It is also unaffected by external disturbances such as protruding welds and side taps.

Single rigid probes are suitable for chamber installations. When used in a metal, small diameter pipe, single rigid probes offer a stronger return signal than when used in open applications. This makes them suitable for low dielectric and interface applications. In addition, for applications with highly viscous media where build up is likely to occur, single rigid probes is the best choice.

Single flexible probes may be used in longer bypass chambers, but care must be taken to ensure that the probe is suspended in a true vertical position and does not touch the pipe wall. If flexible probes are to be used, the bypass chambers should be 4 in. (100 mm) or larger in diameter to allow room for some flexing.

The probe must not touch the chamber wall, should extend the full height of the chamber, but not touch the bottom of the chamber. The probe length determines if a single rigid or single flexible probe should be used:

- Less than 19.7 ft. (6.0 m): Rigid single probe is recommended. Use a centering disc for probe > 3.3 ft. (1 m). When mounting space is limited, use a flexible single probe with a weight and centering disc.
- More than 19.7 ft. (6.0 m): Use flexible single probe with a weight and centering disc.⁽¹¹⁾

Centering disc for pipe installations

To prevent the probe from contacting the chamber or pipe wall, centering discs are available for flexible single, rigid single, and flexible twin lead probes. The disc is attached to the end of the probe. Discs are made of stainless steel, Alloy C-276, Alloy 825, Duplex 2205, or PTFE. The centering disc in PTFE is not available for HTHP probes.

For the segmented rigid single lead probe, up to five PTFE centering discs can be mounted along the probe, but keep a minimum distance of two segments between the discs. Additionally, a disc in SST or PTFE (part number 03300-1655-xxxx) can be attached to the end of the probe.

When mounting a centering disc, it is important that it fits correctly in the chamber/pipe. See [Figure 31](#) for Dimension D. [Table 35](#) shows which centering disc diameter to choose for a particular pipe. [Table 36](#) shows which centering disc diameter to choose for a Rosemount chamber.

Figure 31: Dimension D for Centering Discs

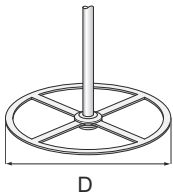

Table 34: Centering Disc Dimensions

Disc size	Actual disc diameter (D)
2-in.	1.8 in. (45 mm)
3-in.	2.7 in. (68 mm)
4-in.	3.6 in. (92 mm)
6-in.	5.55 in. (141 mm)
8-in.	7.40 in. (188 mm)

(11) The Blind Zones and the height of the weight limit the use of single flexible probes shorter than 3 ft. (1 m). If using the flexible probe, the short weight is recommended.

Table 35: Centering Disc Size Recommendation for Different Pipe Schedules

Pipe size	Pipe schedule			
	5s, 5 and 10s, 10	40s, 40 and 80s, 80	120	160
2-in.	2-in.	2-in.	N/A ⁽¹⁾	N/A ⁽²⁾
3-in.	3-in.	3-in.	N/A ⁽¹⁾	2-in.
4-in.	4-in.	4-in.	4-in.	3-in.
5-in.	4-in.	4-in.	4-in.	4-in.
6-in.	6-in.	6-in.	4-in.	4-in.
7-in.	N/A ⁽¹⁾	6-in.	N/A ⁽¹⁾	N/A ⁽¹⁾
8-in.	8-in.	8-in.	6-in.	6-in.

(1) Schedule is not available for pipe size.

(2) No centering disc is available.

Table 36: Centering Disc Size Recommendations for Rosemount Chambers

Chamber size	Chamber rating	Centering disc
3-in.	Up to Class 600/PN 100	3-in.
	Class 900, 1500/PN160, 250	2-in.
3-in. T-piece	Up to Class 600/PN 100	2-in.
4-in.	Up to Class 600/PN 100	4-in.
	Class 900, 1500/PN160, 250	3-in.

Product certifications

Rev 10.29

European directive information

A copy of the EU Declaration of Conformity can be found at the end of the Quick Start Guide. The most recent revision of the EU Declaration of Conformity can be found at Emerson.com/Rosemount.

Safety Instrumented Systems (SIS)

SIL 3 Capable: IEC 61508 certified for use in safety instrumented systems up to SIL 3 (Minimum requirement of single use (1oo1) for SIL 2 and redundant use (1oo2) for SIL 3).

Ordinary location certification

As standard, the transmitter has been examined and tested to determine that the design meets the basic electrical, mechanical, and fire protection requirements by a nationally recognized test laboratory (NRTL) as accredited by the Federal Occupational Safety and Health Administration (OSHA).

Installing equipment in North America

The US National Electrical Code® (NEC) and the Canadian Electrical Code (CEC) permit the use of Division marked equipment in Zones and Zone marked equipment in Divisions. The markings must be suitable for the area classification, gas, and temperature class. This information is clearly defined in the respective codes.

USA

E5 Explosionproof (XP), Dust-Ignitionproof (DIP)

Certificate	FM16US0444X
Standards	FM Class 3600 – 2018; FM Class 3610 – 2010; FM Class 3611 – 2004; FM Class 3615 – 2006; FM Class 3810 – 2005; ANSI/ISA 60079-0 – 2013; ANSI/ISA 60079-11 – 2012; ANSI/NEMA® 250 – 2003;
Markings	XP CLI, DIV 1, GP B, C, D; DIP CLII/III, DIV 1, GP E, F, G; T4; -50 °C ≤ Ta ≤ 60 °C (FIELDBUS) / 70 °C (HART); Type 4X

Special Conditions for Safe Use (X):

1. WARNING – Potential Electrostatic Charging Hazard – The enclosure contains non-metallic material. To prevent the risk for electrostatic sparking the plastic surface should only be cleaned with a damp cloth.
2. WARNING – The apparatus enclosure contains aluminum and is considered to constitute a potential risk of ignition by impact or friction. Care must be taken into account during installation and use to prevent impact or friction.
3. With the Operating Temperature and Pressure code P, the installer shall consider the effect of process temperature and ensure that the maximum specified ambient temperature of +70°C for HART (+60°C for Fieldbus) is not exceeded at process temperatures of up to +260°C (+500°F).

IS Intrinsic Safety (IS), Nonincendive (NI)

- Certificate** FM16US0444X
- Standards** FM Class 3600 – 2018; FM Class 3610 – 2010; FM Class 3611 – 2004; FM Class 3615 – 2006; FM Class 3810 – 2005; ANSI/ISA 60079-0 – 2013; ANSI/ISA 60079-11 – 2012; ANSI/NEMA 250 – 2003;
- Markings** IS CL I, II, III, DIV 1, GP A, B, C, D, E, F, G in accordance with control drawing 9240030-936; IS (Entity) CL I, Zone 0, AEx ia IIC T4 in accordance with control drawing 9240030-936, NI CL I, II, III DIV 2, GP A, B, C, D, F, G; T4; $-50^{\circ}\text{C} \leq T_a \leq 60^{\circ}\text{C}$ (FIELDBUS) / 70°C (HART); Type 4X

Special Conditions for Safe Use (X):

1. WARNING – Potential Electrostatic Charging Hazard – The enclosure contains non-metallic material. To prevent the risk for electrostatic sparking the plastic surface should only be cleaned with a damp cloth.
2. WARNING – The apparatus enclosure contains aluminum and is considered to constitute a potential risk of ignition by impact or friction. Care must be taken into account during installation and use to prevent impact or friction.
3. With the Operating Temperature and Pressure code P, the installer shall consider the effect of process temperature and ensure that the maximum specified ambient temperature of $+70^{\circ}\text{C}$ for HART ($+60^{\circ}\text{C}$ for Fieldbus) is not exceeded at process temperatures of up to $+260^{\circ}\text{C}$ ($+500^{\circ}\text{F}$).

	Ui	Ii	Pi	Ci	Li
Entity parameters HART	30 V	130 mA	1 W	7.26 nF	0
Entity parameters Fieldbus	30 V	300 mA	1.3 W	0	0

IE FISCO

- Certificate** FM16US0444X
- Standards** FM Class 3600 – 2018; FM Class 3610 – 2010; FM Class 3611 – 2004; FM Class 3615 – 2006; FM Class 3810 – 2005; ANSI/ISA 60079-0 – 2013; ANSI/ISA 60079-11 – 2012; ANSI/NEMA 250 – 2003;
- Markings** IS CL I, II, III, DIV 1, GP A, B, C, D, E, F, G; T4; in accordance with control drawing 9240030-936; IS CL I, Zone 0 AEx ia IIC T4 in accordance with control drawing 9240030-936; $-50^{\circ}\text{C} \leq T_a \leq 60^{\circ}\text{C}$; Type 4X

Special Conditions for Safe Use (X):

1. WARNING – Potential Electrostatic Charging Hazard – The enclosure contains non-metallic material. To prevent the risk for electrostatic sparking the plastic surface should only be cleaned with a damp cloth.
2. WARNING – The apparatus enclosure contains aluminum and is considered to constitute a potential risk of ignition by impact or friction. Care must be taken into account during installation and use to prevent impact or friction.
3. With the Operating Temperature and Pressure code P, the installer shall consider the effect of process temperature and ensure that the maximum specified ambient temperature of $+70^{\circ}\text{C}$ for HART ($+60^{\circ}\text{C}$ for Fieldbus) is not exceeded at process temperatures of up to $+260^{\circ}\text{C}$ ($+500^{\circ}\text{F}$).

	Ui	Ii	Pi	Ci	Li
FISCO parameters	17.5 V	380 mA	5.32 W	0	0

Canada

E6 Explosionproof, Dust-Ignitionproof

- Certificate** 1514653

Standards	CSA C22.2 No.0-M91, CSA C22.2 No.25-1966, CSA C22.2 No.30-M1986, CSA C22.2 No.94-M91, CSA C22.2 No.142-M1987, CSA C22.2 157-92, CAN/CSA C22.2 No. 60529:05, ANSI/ISA 12.27.01-2003
Markings	Explosionproof CL I, DIV 1, GP B, C, D; Dust-Ignitionproof CL II, DIV 1, GP E, F, G and coal dust, CL III, DIV 1, Type 4X/IP66/IP67 Maximum Ambient Temperature +60 °C for Fieldbus and FISCO and +70 °C for HART

I6 Intrinsically Safe and Non-Incendive Systems

Certificate	1514653
Standards	CSA C22.2 No.0-M91, CSA C22.2 No.25-1966, CSA C22.2 No.30-M1986, CSA C22.2 No.94-M91, CSA C22.2 No.142-M1987, CSA C22.2 157-92, CAN/CSA C22.2 No. 60529:05, ANSI/ISA 12.27.01-2003
Markings	CL I, DIV 1, GP A, B, C, D, T4 see installation drawing 9240030-937; Non-Incendive Class III, DIV 1, Haz-loc CL I DIV 2, GP A, B, C, D, Maximum Ambient Temperature +60 °C for Fieldbus and FISCO and +70 °C for HART, T4, Type 4X/IP66/IP67, Maximum Working Pressure 5000 psi, Dual Seal.

	Ui	Ii	Pi	Ci	Li
Entity parameters HART	30 V	130 mA	1 W	7.26 nF	0
Entity parameters Fieldbus	30 V	300 mA	1.3 W	0	0

IF FISCO

Certificate	1514653
Standards	CSA C22.2 No.0-M91, CSA C22.2 No.25-1966, CSA C22.2 No.30-M1986, CSA C22.2 No.94-M91, CSA C22.2 No.142-M1987, CSA C22.2 157-92, CAN/CSA C22.2 No. 60529:05, ANSI/ISA 12.27.01-2003
Markings	CL I, DIV 1, GP A, B, C, D, T4 see installation drawing 9240030-937; Non-Incendive Class III, DIV 1, Haz-loc CL I DIV 2, GP A, B, C, D, Maximum Ambient Temperature +60 °C, T4, Type 4X/IP66/IP67, Maximum Working Pressure 5000 psi, Dual Seal.

	Ui	Ii	Pi	Ci	Li
FISCO parameters	17.5 V	380 mA	5.32 W	0	0

Europe

E1 ATEX Flameproof

Certificate	Nemko 04ATEX1073X
Standards	EN 60079-0:2018 / EN 60079-0:2012/A11:2013, EN 60079-1:2014, EN 60079-11:2012, EN 60079-26:2015, EN 60079-31:2014
Markings	<p>⊕ II 1/2G Ex db ia IIC T4 Ga/Gb, -55 °C ≤ Ta ≤ +60 °C (FIELDBUS) / +70 °C (HART)</p> <p>⊕ II 1D Ex ta IIIC T69 °C (FIELDBUS) / T79 °C (HART) Da -40 °C ≤ Ta ≤ +60 °C (FIELDBUS) / +70 °C (HART)</p> <p>Um = 250 V</p>

Special Conditions for Safe Use (X):

1. Potential ignition hazards by impact or friction need to be considered according to EN 60079-0:2018 clause 8.3 (for EPL Ga and EPL Gb), and clause 8.4 (for EPL Da and EPL Db), when the transmitter enclosure and antennas exposed to the exterior atmosphere of the tank, is made with light metals containing aluminium or titanium. The end user shall determine the suitability with regard to avoid hazards from impact and friction.

2. Parts of the sensor probes, for type 5300, are non-conducting material covering metal surfaces. The area of the non-conducting part exceeds the maximum permissible areas for Group III according to EN 60079-0: 2018 clause 7.4.3. Therefore, when the probe is used in a potentially explosive atmosphere group III, EPL Da, appropriate measures must be taken to prevent electrostatic discharge.
3. The painted transmitter housing is non-conducting and exceeds the maximum permissible areas for Group III according to EN 60079-0: 2018 clause 7.4:3. Therefore, when the probe is used in a potentially dust explosive atmosphere group III, appropriate measures must be taken to prevent electrostatic discharge (i.e. only clean with a damp cloth).
4. 1/2” NPT threads need to be sealed for dust and water ingress protection, IP 66, IP 67 or “Ex t”. EPL Da or Db is required.

I1 ATEX Intrinsic Safety

- Certificate** Nemko 04ATEX1073X
- Standards** EN 60079-0:2018 / EN 60079-0:2012/A11:2013, EN 60079-1:2014, EN 60079-11:2012, EN 60079-26:2015, EN 60079-31:2014
- Markings**
 - ⊕ II 1G Ex ia IIC T4 Ga, -55 °C ≤ Ta ≤ +60 °C (FIELDBUS) /+70 °C (HART)
 - ⊕ II 1D Ex ia IIIC T69 °C/T79 °C Da, -50 °C ≤ Ta ≤ +60 °C (FIELDBUS) /+70 °C (HART)

Special Conditions for Safe Use (X):

1. The intrinsically safe circuits do not withstand the 500V AC test as specified in EN 60079-11:2012 clause 6.3.13.
2. Potential ignition hazards by impact or friction need to be considered according to EN 60079-0:2018 clause 8.3 (for EPL Ga and EPL Gb), and clause 8.4 (for EPL Da and EPL Db), when the transmitter enclosure and antennas exposed to the exterior atmosphere of the tank, is made with light metals containing aluminium or titanium. The end user shall determine the suitability with regard to avoid hazards from impact and friction.
3. Parts of the sensor probes, for type 5300, are non-conducting material covering metal surfaces. The area of the non-conducting part exceeds the maximum permissible areas for Group III according to EN 60079-0: 2018 clause 7.4.3. Therefore, when the antenna is used in a potentially explosive atmosphere group III, EPL Da, appropriate measures must be taken to prevent electrostatic discharge.
4. The painted transmitter housing is non-conducting and exceeds the maximum permissible areas for Group III according to EN 60079-0: 2018 clause 7.4:3. Therefore, when the probe is used in a potentially dust explosive atmosphere group III, appropriate measures must be taken to prevent electrostatic discharge (i.e. only clean with a damp cloth).
5. 1/2” NPT threads need to be sealed for dust and water ingress protection, IP 66, IP 67 or “Ex t”. EPL Da or Db is required.

	Ui	Ii	Pi	Ci	Li
Entity parameters HART	30 V	130 mA	1 W	7.26 nF	0
Entity parameters Fieldbus	30 V	300 mA	1.5 W	4.95 nF	0

IA ATEX FISCO

- Certificate** Nemko 04ATEX1073X
- Standards** EN 60079-0:2018 / EN 60079-0:2012/A11:2013, EN 60079-1:2014, EN 60079-11:2012, EN 60079-26:2015, EN 60079-31:2014
- Markings**
 - ⊕ II 1G Ex ia IIC T4 Ga (-55 °C ≤ Ta ≤ +60 °C) or
 - ⊕ II 1/2G Ex ia/ib IIC T4 Ga/Gb (-55 °C ≤ Ta ≤ +60 °C)
 - ⊕ II 1D Ex ia IIIC T69 °C Da, (-50 °C ≤ Ta ≤ +60 °C)
 - ⊕ II 1D Ex ia/ib IIIC T69 °C Da/Db, (-50 °C ≤ Ta ≤ +60 °C)

Special Conditions for Safe Use (X):

1. The intrinsically safe circuits do not withstand the 500V AC test as specified in EN 60079-11:2012 clause 6.3.13.

2. Potential ignition hazards by impact or friction need to be considered according to EN 60079-0:2018 clause 8.3 (for EPL Ga and EPL Gb), and clause 8.4 (for EPL Da and EPL Db), when the transmitter enclosure and antennas exposed to the exterior atmosphere of the tank, is made with light metals containing aluminium or titanium. The end user shall determine the suitability with regard to avoid hazards from impact and friction.
3. Parts of the sensor probes, for type 5300, are non-conducting material covering metal surfaces. The area of the non-conducting part exceeds the maximum permissible areas for Group III according to EN 60079-0: 2018 clause 7.4.3 Therefore, when the antenna is used in a potentially explosive atmosphere group III, EPL Da, appropriate measures must be taken to prevent electrostatic discharge.
4. The painted transmitter housing is non-conducting and exceeds the maximum permissible areas for Group III according to EN 60079-0: 2018 clause 7.4:3.. Therefore, when the probe is used in a potentially dust explosive atmosphere group III, appropriate measures must be taken to prevent electrostatic discharge (i.e. only clean with a damp cloth).
5. The Ex ia version of model 5300 FISCO device may be supplied by an “Ex ib” FISCO power supply, when the power supply is certified with three separate safety current limiting devices and voltage limitation which meets the requirements for type Ex ia.
6. 1/2” NPT threads need to be sealed for dust and water ingress protection, IP 66, IP 67 or “Ex t”. EPL Da or Db is required.

	Ui	Ii	Pi	Ci	Li
FISCO parameters	17.5 V	380 mA	5.32 W	4.95 nF	<1 µH

N1 ATEX Type N

- Certificate** Nemko 10ATEX1072X
- Standards** EN 60079-0:2012+A11:2013, EN 60079-11:2012, EN 60079-15:2010, EN 60079-31:2014
- Markings** Ⓢ II 3G Ex nA ic IIC T4 Gc
 Ⓢ II 3G Ex ic IIC T4 Gc
 Ⓢ II 3D Ex tc IIIC T69 °C (FIELDBUS) /T79 °C (HART) Dc
 -50 °C ≤ Ta ≤ +60 °C (FIELDBUS) /+70 °C (HART)

Special Conditions for Safe Use (X):

1. The transmitter circuits does not withstand 500V AC dielectric strength test according to EN 60079-11 clause 6.3.13 due to earth connected transient suppressing devices. Appropriate measures have to be considered by installation.

	Ui	Ii	Pi	Ci	Li
Safety parameters HART	42.4 V	23 mA	1 W	7.25 nF	Negligible
Safety parameters Fieldbus	32 V	21 mA	0.7 W	4.95 nF	Negligible

International

E7 IECEx Flameproof

- Certificate** IECEx NEM 06.0001X
- Standards** IEC 60079-0:2011, IEC 60079-1:2014-06, IEC 60079-11:2011, IEC 60079-26:2014, IEC 60079-31:2013
- Markings** Ex db ia IIC T4 Ga/Gb
 -55 °C ≤ Ta ≤ +60 °C (FIELDBUS) /+70 °C (HART)
 Ex ta IIIC T69 °C (FIELDBUS) /T79 °C (HART) Da
 -40 °C ≤ Ta ≤ +60 °C (FIELDBUS) /+70 °C (HART)

Um=250 VAC, IP66/IP67

Special Conditions for Safe Use (X):

1. Potential ignition hazards by impact or friction need to be considered according to IEC 60079-0:2011 clause 8.3 (for EPL Ga and EPL Gb), and clause 8.4 (for EPL Da and EPL Db), when the transmitter enclosure and antennas exposed to the exterior atmosphere of the tank, is made with light metals containing aluminium or titanium. The end user shall determine the suitability with regard to avoid hazards from impact and friction.
2. Parts of the sensor probes for type 5300 are non-conducting material covering metal surfaces and the area of the non-conducting part exceeds the maximum permissible areas for Group III according to IEC 60079-0: 2011 clause 7.4:3. Therefore, when the antenna is used in a potentially explosive atmosphere group III, EPL Da, appropriate measures must be taken to prevent electrostatic discharge.
3. The painted transmitter housing is non-conducting and exceeds the maximum permissible areas for Group III according to IEC 60079-0: 2011 clause 7.4:3. Therefore, when the probe is used in a potentially dust explosive atmosphere group III, appropriate measures must be taken to prevent electrostatic discharge (i.e. only clean with a damp cloth).
4. ½” NPT threads need to be sealed for dust and water ingress protection, IP 66, IP 67 or “Ex t”. EPL Da or Db is required.

I7 IECEx Intrinsic Safety

Certificate IECEx NEM 06.0001X
Standards IEC 60079-0:2011, IEC 60079-1:2014-06, IEC 60079-11:2011, IEC 60079-26:2014, IEC 60079-31:2013
Markings Ex ia IIC T4 Ga
 -55 °C ≤ Ta ≤ +60 °C (FIELDBUS) /+70 °C (HART)
 Ex ia IIIC T69 °C/T79 °C Da
 -50 °C ≤ Ta ≤ +60 °C (FIELDBUS) /+70 °C (HART)

Special Conditions for Safe Use (X):

1. The intrinsically safe circuits do not withstand the 500V AC test as specified in IEC 60079-11 clause 6.3.13.
2. Potential ignition hazards by impact or friction need to be considered according to IEC 60079-0:2011 clause 8.3 (for EPL Ga and EPL Gb), and clause 8.4 (for EPL Da and EPL Db), when the transmitter enclosure and antennas exposed to the exterior atmosphere of the tank, is made with light metals containing aluminium or titanium. The end user shall determine the suitability with regard to avoid hazards from impact and friction.
3. Parts of the sensor probes for type 5300 are non-conducting material covering metal surfaces and the area of the non-conducting part exceeds the maximum permissible areas for Group III according to IEC 60079-0: 2011 clause 7.4:3. Therefore, when the antenna is used in a potentially explosive atmosphere group III, EPL Da, appropriate measures must be taken to prevent electrostatic discharge.
4. The painted transmitter housing is non-conducting and exceeds the maximum permissible areas for Group III according to IEC 60079-0: 2011 clause 7.4:3. Therefore, when the probe is used in a potentially dust explosive atmosphere group III, appropriate measures must be taken to prevent electrostatic discharge (i.e. only clean with a damp cloth).
5. ½” NPT threads need to be sealed for dust and water ingress protection, IP 66, IP 67 or “Ex t”. EPL Da or Db is required.

	Ui	Ii	Pi	Ci	Li
Entity parameters HART	30 V	130 mA	1 W	0 µF	Negligible
Entity parameters Fieldbus	30 V	300 mA	1.5 W	4.95 nF	Negligible

IG IECEx FISCO

Certificate IECEx NEM 06.0001X
Standards IEC 60079-0:2011, IEC 60079-1:2014-06, IEC 60079-11:2011, IEC 60079-26:2014, IEC 60079-31:2013

Markings	Ex ia IIC T4 Ga (-55 °C ≤ Ta ≤ +60 °C)
	Ex ia/ib IIC T4 Ga/Gb (-55 °C ≤ Ta ≤ +60 °C)
	Ex ia IIIC T69 °C Da (-50 °C ≤ Ta ≤ +60 °C)
	Ex ia/ib IIIC T69 °C Da/Db (-50 °C ≤ Ta ≤ +60 °C)

Special Conditions for Safe Use (X):

1. The intrinsically safe circuits do not withstand the 500V AC test as specified in IEC 60079-11 clause 6.3.13.
2. Potential ignition hazards by impact or friction need to be considered according to IEC 60079-0:2011 clause 8.3 (for EPL Ga and EPL Gb), and clause 8.4 (for EPL Da and EPL Db), when the transmitter enclosure and antennas exposed to the exterior atmosphere of the tank, is made with light metals containing aluminium or titanium. The end user shall determine the suitability with regard to avoid hazards from impact and friction.
3. Parts of the sensor probes for type 5300 are non-conducting material covering metal surfaces and the area of the non-conducting part exceeds the maximum permissible areas for Group III according to IEC 60079-0: 2011 clause 7.4:3. Therefore, when the antenna is used in a potentially explosive atmosphere group III, EPL Da, appropriate measures must be taken to prevent electrostatic discharge.
4. The painted transmitter housing is non-conducting and exceeds the maximum permissible areas for Group III according to IEC 60079-0: 2011 clause 7.4:3. Therefore, when the probe is used in a potentially dust explosive atmosphere group III, appropriate measures must be taken to prevent electrostatic discharge (i.e. only clean with a damp cloth).
5. The Ex ia version of model 5300 FISCO field device may be supplied by an [Ex ib] FISCO power supply when the power supply is certified with three separate safety current limiting devices and voltage limitation which meets the requirements for type Ex ia.
6. ½” NPT threads need to be sealed for dust and water ingress protection, IP 66, IP 67 or “Ex t”, EPL Da or Db is required.

	Ui	Ii	Pi	Ci	Li
FISCO parameters	17.5 V	380 mA	5.32 W	4.95 nF	<1 μH

N7 IECEx Type N

Certificate	IECEx NEM 10.0005X
Standards	IEC 60079-0:2011, IEC 60079-11:2011, IEC 60079-15:2010, IEC 60079-31:2013
Markings	Ex nA ic IIC T4 Gc Ex ic IIC T4 Gc Ex tc IIIC T69 °C (FIELDBUS) /T79 °C (HART) Dc -50 °C ≤ Ta ≤ +60 °C (FIELDBUS) /+70 °C (HART)

Special Conditions for Safe Use (X):

1. The transmitter circuits does not withstand 500V AC dielectric strength test according to EN 60079-11 clause 6.3.13 due to earth connected transient suppressing devices. Appropriate measures have to be considered by installation.

	Ui	Ii	Pi	Ci	Li
Safety parameters HART	42.4 V	23 mA	1 W	7.25 nF	Negligible
Safety parameters Fieldbus	32 V	21 mA	0.7 W	4.95 nF	Negligible

Brazil

E2 INMETRO Flameproof

Certificate UL-BR 17.0188X

Standards ABNT NBR IEC 60079-0:2013, ABNT NBR IEC 60079-1:2016, ABNT NBR IEC 60079-11:2013, ABNT NBR IEC 60079-26:2016, ABNT NBR IEC 60079-31:2014

Markings Ex db ia IIC T4 Ga/Gb (-55 °C ≤ T_{amb} ≤ +60 °C /+70 °C)
 Ex ta IIIC T69 °C/T79 °C Da (-40 °C ≤ T_{amb} ≤ +60 °C /+70 °C)
 Um=250 V_{ac}, IP66/67

Special Conditions for Safe Use (X):

1. See certificate for Specific Conditions.

I2 INMETRO Intrinsic Safety

Certificate Certificate: UL-BR 17.0188X

Standards ABNT NBR IEC 60079-0:2013 , ABNT NBR IEC 60079-11:2013, ABNT NBR IEC 60079-26:2016, ABNT NBR IEC 60079-31:2014

Markings Ex ia IIC T4 Ga (- 55 °C ≤ T_{amb} ≤ +60 °C /+70 °C)
 Ex ia IIIC T69 °C/T79 °C Da (- 50 °C ≤ T_{amb} ≤ +60 °C /+70 °C)

Special Conditions for Safe Use (X):

1. See certificate for Specific Conditions.

	Ui	Ii	Pi	Ci	Li
Entity parameters HART	30 V _{dc}	130 mA	1.0 W	7.26 nF	Negligible
Entity parameters Fieldbus	30 V _{dc}	300 mA	1.5 W	4.95 nF	Negligible

IB INMETRO FISCO

Certificate UL-BR 17.0188X

Standards ABNT NBR IEC 60079-0:2013, ABNT NBR IEC 60079-11:2013, ABNT NBR IEC 60079-26:2016, ABNT NBR IEC 60079-31:2014

Markings Ex ia IIC T4 Ga (- 55 °C ≤ T_{amb} ≤ +60 °C)
 Ex ia/ib IIC T4 Ga/Gb (- 55 °C ≤ T_{amb} ≤ +60 °C)
 Ex ia IIIC T69 °C Da (- 50 °C ≤ T_{amb} ≤ +60 °C)
 Ex ia/ib IIIC T69 °C Da/Db (- 50 °C ≤ T_{amb} ≤ +60 °C)

Special Conditions for Safe Use (X):

1. See certificate for Specific Conditions.

	Ui	Ii	Pi	Ci	Li
FISCO parameters	17.5 V _{dc}	380 mA	5.32 W	4.95 nF	<1 μH

China

E3 China Flameproof

Certificate	GYJ20.1621X
Standards	GB 3836.1/2/4/20-2010, GB 12476.1/5-2013, GB 12476.4-2010
Markings	Ex d ia IIC T4 Ga/Gb (-55 °C ≤ Ta ≤ +60 °C/+70 °C) Ex tD A20 IP 66/67 T69 °C /T79 °C (-40 °C ≤ Ta ≤ +60 °C/+70 °C)

Special Conditions for Safe Use (X):

1. See certificate for Specific Conditions.

I3 China Intrinsic Safety

Certificate	GYJ20.1621X
Standards	GB 3836.1/2/4/20-2010, GB 12476.1/5-2013, GB 12476.4-2010
Markings	Ex ia IIC T4 Ga (-55 °C ≤ Ta ≤ +60 °C/+70 °C) Ex iaD 20 T69 °C /T79 °C (-50 °C ≤ Ta ≤ +60 °C/+70 °C)

Special Conditions for Safe Use (X):

1. See certificate for Specific Conditions.

	Ui	Ii	Pi	Ci	Li
Entity parameters HART	30 V	130 mA	1 W	7.26 nF	0 mH
Entity parameters Fieldbus	30 V	300 mA	1.5 W	4.95 nF	0 mH

IC China FISCO

Certificate	GYJ20.1621X
Standards	GB 3836.1/2/4/20-2010, GB 12476.4/5-2013, GB 12476.1-2010
Markings	Ex ia IIC T4 Ga (-55 °C ≤ Ta ≤ +60 °C) Ex ia/ib IIC T4 Ga/Gb (-55 °C ≤ Ta ≤ +60 °C) Ex iaD 20 T69 (-50 °C ≤ Ta ≤ +60 °C) Ex iaD/ibD 20/21 T69 °C (-50 °C ≤ Ta ≤ +60 °C)

Special Conditions for Safe Use (X):

1. See certificate for Specific Conditions.

	Ui	Ii	Pi	Ci	Li
FISCO parameters	17.5 V	380 mA	5.32 W	4.95 nF	<0.001 mH

N3 China Type N

Certificate	GYJ18.1331X
Standards	GB 3836.1-2010, GB 3836.4-2010, GB 3836.8-2014
Markings	Ex nA ic IIC T4 Gc (-50 °C ≤ Ta ≤ +60 °C/+70 °C)

Ex ic IIC T4 Gc (-50 °C ≤ Ta ≤ +60 °C/+70 °C)

Special Conditions for Safe Use (X):

1. See certificate for Specific Conditions.

	Ui	Ii	Pi	Ci	Li
Safety parameters HART	42.4 V	23 mA	1 W	7.25 nF	Negligible
Safety parameters Fieldbus	32 V	21 mA	0.7 W	4.95 nF	Negligible

Technical Regulations Customs Union (EAC)

TR CU 020/2011 “Electromagnetic Compatibility of Technical Products”

TR CU 032/2013 “On safety of equipment and vessels under pressure”

Certificate RU C-US.AД07.B.00770/19

TR CU 012/2011 “On safety of equipment intended for use in explosive atmospheres”

EM Technical Regulations Customs Union (EAC) Flameproof

Certificate EAЭC RU C-SE.EX01.B.0086/19

Markings Ga/Gb Ex db ia IIC T4...T1 X, (-55 °C ≤ Ta ≤ +60 °C/+70 °C)
Ex ta IIIC T69 °C/T79 °C Da X (-40 °C ≤ Ta ≤ +60 °C/+70 °C)

Special Conditions for Safe Use (X):

1. See certificate for Specific Conditions.

IM Technical Regulations Customs Union (EAC) Intrinsic Safety

Certificate EAЭC RU C-SE.EX01.B.0086/19

Markings 0Ex ia IIC T4...T1 Ga X, (-55 °C ≤ Ta ≤ +60 °C/+70 °C)
Ex ia IIIC T69 °C/T79 °C Da X, (-50 °C ≤ Ta ≤ +60 °C/+70 °C)

Special Conditions for Safe Use (X):

1. See certificate for Specific Conditions.

	Ui	Ii	Pi	Ci	Li
Entity parameters HART	30 V	130 mA	1 W	7.26 nF	0 mH
Entity parameters Fieldbus	30 V	300 mA	1.5 W	4.95 nF	0 mH

IN Technical Regulations Customs Union (EAC) FISCO

Certificate EAЭC RU C-SE.EX01.B.0086/19

Markings 0Ex ia IIC T4...T1 Ga X, (-55 °C ≤ Ta ≤ +60 °C)
Ga/Gb Ex ia/ib IIC T4...T1 X, (-55 °C ≤ Ta ≤ +60 °C)
Ex ia IIIC T69 °C Da X, (-50 °C ≤ Ta ≤ +60 °C)
Ex ia/ib IIIC T69 °C Da/Db X, (-50 °C ≤ Ta ≤ +60 °C)

Special Conditions for Safe Use (X):

1. See certificate for Specific Conditions.

	Ui	Ii	Pi	Ci	Li
FISCO parameters	17.5 V	380 mA	5.32 W	4.95 nF	0 mH

Japan

E4 Flameproof

Certificate CML 17JPN1334X

Markings Ex d ia IIC T4 Ga/Gb (-40 °C ≤ Ta ≤ +60 °C/+70 °C)

Special Conditions for Safe Use (X):

1. See certificate for Specific Conditions.

Republic of Korea

EP Flameproof HART

Certificate KTL 15-KB4BO-0297X, 13-KB4BO-0019X

Markings Ex d ia IIC T4 Ga/Gb

Special Conditions for Safe Use (X):

1. See certificate for Specific Conditions.

EP Flameproof Fieldbus

Certificate KTL 12-KB4BO-0179X

Markings Ex d ia IIC T4

Special Conditions for Safe Use (X):

1. See certificate for Specific Conditions.

India

Flameproof, Intrinsically safe

Certificate P392482/1

Markings Ex db ia IIC T4 Ga /Gb
Ex ia IIC T4 Ga

Special Conditions for Safe Use (X):

1. See certificate for Specific Conditions.

United Arab Emirates

Flame-proof

Certificate	20-11-28736/Q20-11-001012
Markings	Same as IECEx (E7)

Intrinsic Safety

Certificate	20-11-28736/Q20-11-001012
Markings	Same as IECEx (I7)

FISCO

Certificate	20-11-28736/Q20-11-001012
Markings	Same as IECEx (IG)

Ukraine

Flameproof, Intrinsically Safe

Certificate	UA.TR.047.C.0352-13
Markings	0 Ex ia IIC T4 X, 1 Ex d ia IIC T4 X

Special Conditions for Safe Use (X):

1. See certificate for Specific Conditions.

Uzbekistan

Safety (import)

Certificate	UZ.SMT.01.342.2017121
--------------------	-----------------------

Combinations

KA	Combination of E1, E5 and E6
KB	Combination of E1, E5 and E7
KC	Combination of E1, E6 and E7
KD	Combination of E5, E6 and E7
KE	Combination of I1, I5 and I6
KF	Combination of I1, I5 and I7

KG	Combination of I1, I6 and I7
KH	Combination of I5, I6 and I7
KI	Combination of IA, IE and IF
KJ	Combination of IA, IE and IG
KK	Combination of IA, IF and IG
KL	Combination of IE, IF and IG

Additional certifications

SBS American Bureau of Shipping (ABS) Type Approval

Certificate	20-1974520-1-PDA
Intended Use	For use on ABS Classed Vessels and Offshore Facilities in accordance with ABS rules and International Standards.

Note
Housing material A, Aluminum, is not to be used on open decks.

SBV Bureau Veritas (BV) Type Approval

Certificate	22378_C0 BV
Requirements	Bureau Veritas rules for classification of steel ships. EC Code: 41SB
Application	Class Notations: AUT-UMS, AUT-CCS, AUT-PORT and AUT-IMS.

Note
Housing material A, Aluminum, is not to be used on open decks.

SDN Det Norske Veritas Germanischer Lloyd (DNV GL) Type Approval

Certificate	TAA000020G
Intended Use	DNV GL rules for classification – Ships, offshore units, and high speed and light craft

Table 37: Application

Location classes	
Temperature	D
Humidity	B
Vibration	A
EMC	B
Enclosure	C

Note
Housing material A, Aluminum, is not to be used on open decks.

SKR Korean Register (KR) Type Approval

Certificate CPH05152-AE001

Requirements Pt. 6, Ch. 2, Art. 301 of the Rules for Classification of Steel Ships.

Note

Housing material A, Aluminum, is not to be used on open decks.

SLL Lloyds Register (LR) Type Approval

Certificate LR2002854TA

Application Marine applications for use in environmental categories ENV1, ENV2, ENV3 and ENV5.

Note

Housing material A, Aluminum, is not to be used on open decks.

SNK Nippon Kaiji Kyokai (NK) Type Approval

Certificate TA20555M

Requirements Ch.7, Pt. 6, and Ch. 4, Pt. 7 of “Guidance for the Approval and Type Approval of Materials and Equipment for Marine Use” and the relevant Society’s Rules

Note

Housing material A, Aluminum, is not to be used on open decks.

U1 Overfill prevention

Certificate Z-65.16-476

Application TÜV tested and approved by DIBt for overfill prevention according to the German WHG regulations.

J1 Canadian Registration Number (CRN)

Alberta (ABSA): 0F18507.2, British Columbia (TSBC): 0F6710.1, Manitoba (ITS): 0H6938.4, New Brunswick: 0F1290.97, New Foundland and Labrador: 0F1290.90, Northwest Territories: 0F1290.9T, Nova Scotia: 0F1290.98, Nunavut: 0F1290.9N, Ontario (TSSA): 0F19892.5, Prince Edward Island: 0F1290.9, Quebec (RdBdQ): 0F04826.6, Saskatchewan (TSASK): 0F1870.3, Yukon: 0F1290.9Y

J8 EN Boiler (European Boiler Approval in accordance with EN 12952-11 and EN 12953-9)

Note

Suitable for use as a level sensor part of a limiting device in accordance with EN 12952-11 and EN 12953-9.

QT Safety-certified to IEC 61508:2010 with certificate of FMEDA data

Certificate exida ROS 13-06-005 C001 R2.1

Suitable for intended use

Compliant with NAMUR NE 95, version 22.01.2013 “Basic Principles of Homologation”

Pattern Approval

GOST Belarus

Certificate No. 10263

GOST Kazakhstan

Certificate No. 15466

GOST Russia

Certificate SE.C.29.010.A No.51062/1

GOST Uzbekistan

Certificate 02.7101

Conduit plugs and adapters

IECEx Flameproof and Increased Safety

Certificate IECEX UL 18.0016X

Standards IEC60079-0:2011, IEC60079-1:2014, IEC60079-7:2015, IEC60079-31:2014

Markings Ex db eb IIC Gb; Ex ta IIIC Da

ATEX Flameproof and Increased Safety

Certificate DEMKO 18 ATEX 1986X

Standards EN 60079-0:2012+A11:2013, EN 60079-1:2014, EN 60079-7:2015, EN 60079-31:2014

Markings  II 2 G Ex db eb IIC Gb

 II 1 D Ex ta IIIC Da

Table 38: Conduit Plug Thread Sizes

Thread	Identification mark
M20x1.5-6g	M20
½ - 14 NPT	½ NPT

Table 39: Thread Adapter Thread Sizes

Male thread	Identification mark
M20 x 1.5 – 6g	M20
½- 14 NPT	½ - 14 NPT
Female thread	Identification mark
M20 x 1.5 – 6H	M20
½ - 14 NPT	½ - 14 NPT

Specific Conditions for Safe Use (X):

1. The Blanking Elements shall not be used with an adapter.
2. Only one adapter shall be used with any single cable entry on the associated equipment.
3. It is the end user's responsibility to ensure that the ingress protection rating is maintained at the interface of the equipment and the blanking element/adapter.
4. Suitability of the temperature of the devices is to be determined during end-use with suitably rated equipment.

Dimensional drawings

Figure 32: Rigid Single Lead Probe with Flange Connection

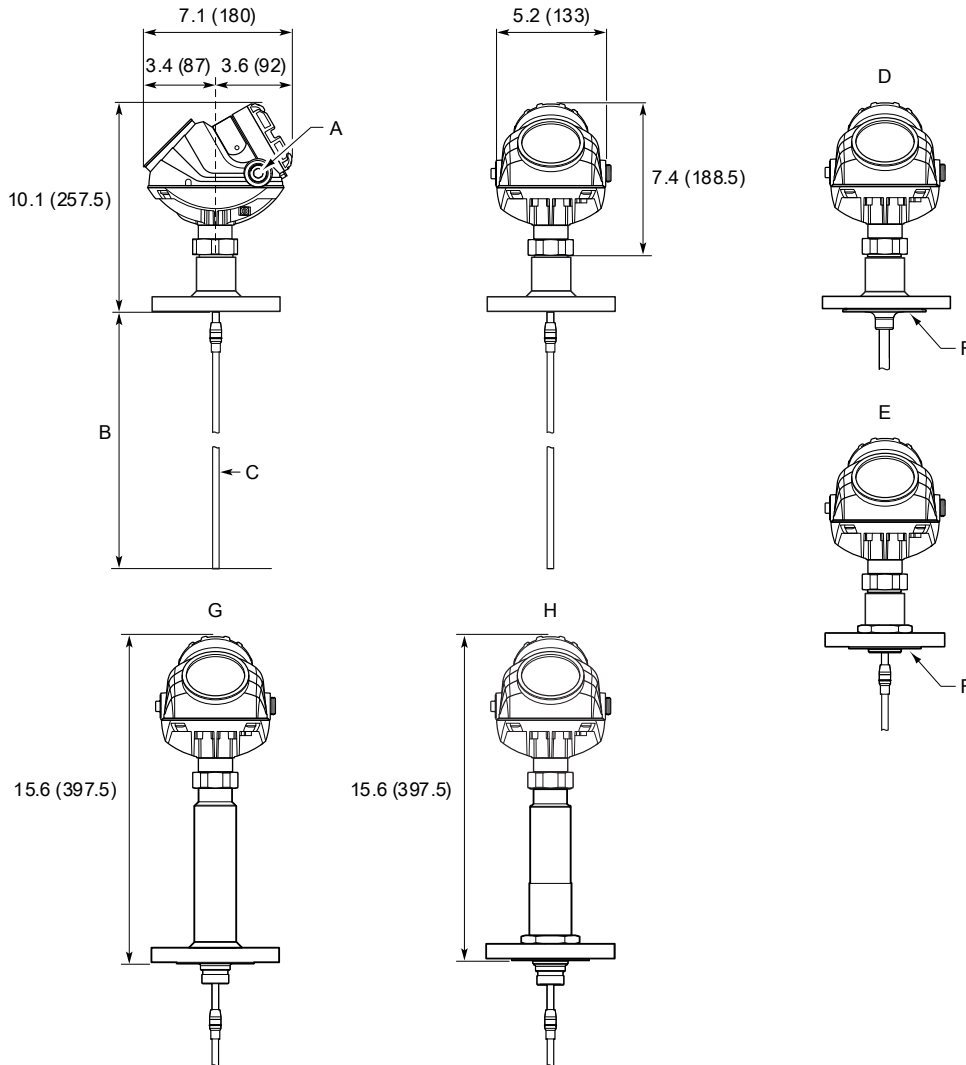

- A. 1/2 - 14 NPT; optional adapters: M20x1.5, eurofast® and minifast®
- B. L ≤ 10 ft. (3 m) for Ø 0.31 (8); L ≤ 20 ft. (6 m) for Ø 0.51 (13)
- C. Ø 0.31 (8); Ø 0.51 (13); Ø 0.47 (12) for PTFE covered probe
- D. PTFE covered probe and protective plate
- E. Alloy probe and protective plate
- F. The PTFE and Alloy probes are designed with a protective plate.
- G. HTHP/HP/C version
- H. HTHP/HP Plate Design (Option for Alloy versions)

Dimensions are in inches (millimeters).

Figure 33: Rigid Single Lead Probe with Tri Clamp Connection

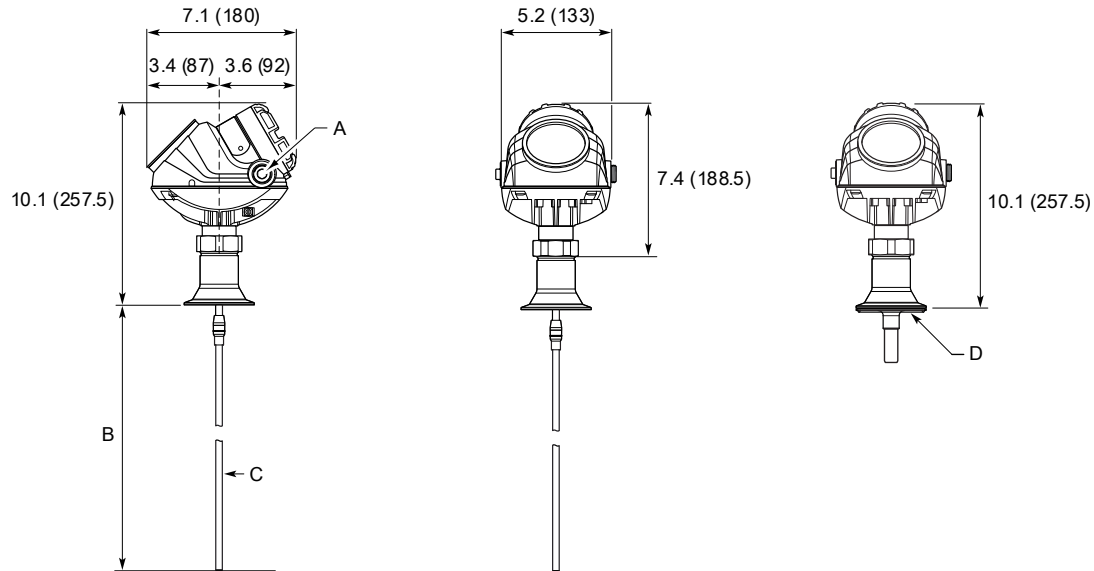

- A. 1/2 - 14 NPT; optional adapters: M20x1.5, eurofast and minifast
- B. L ≤ 10 ft. (3 m) for Ø 0.31 (8); L ≤ 20 ft. (6 m) for Ø 0.51 (13)
- C. Ø 0.31 (8); Ø 0.51 (13); Ø 0.47 (12) for PTFE covered probe
- D. PTFE covered probe and protective plate

Dimensions are in inches (millimeters).

Figure 34: Rigid Single Lead with Threaded Connection

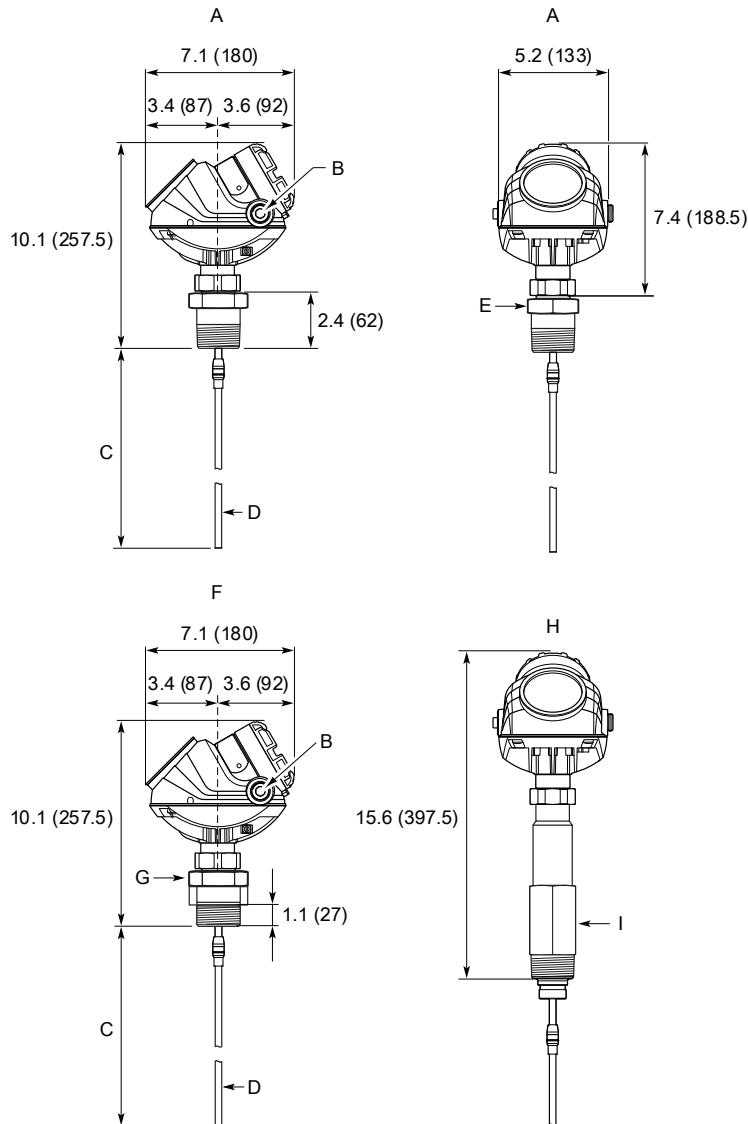

- A. NPT 1 1/2 in.
- B. 1/2 - 14 NPT; optional adapters: M20x1.5, eurofast and minifast
- C. L ≤ 10 ft. (3 m) for Ø 0.31 (8); L ≤ 20 ft. (6 m) for Ø 0.51 (13)
- D. Ø 0.31 (8); Ø 0.51 (13); Ø 0.47 (12) for PTFE covered probe
- E. 1 in. / 1 1/2 in.: s52; 2 in.: s60
- F. G 1 1/2 in.
- G. 1 in.: s52; 1 1/2 in.: s60
- H. NPT 1 1/2, G 1 1/2 in. (HTHP/HP/C version)
- I. NPT: s50; G: s60

Dimensions are in inches (millimeters).

Figure 35: Segmented Rigid Single Lead Probe with Flange Connection

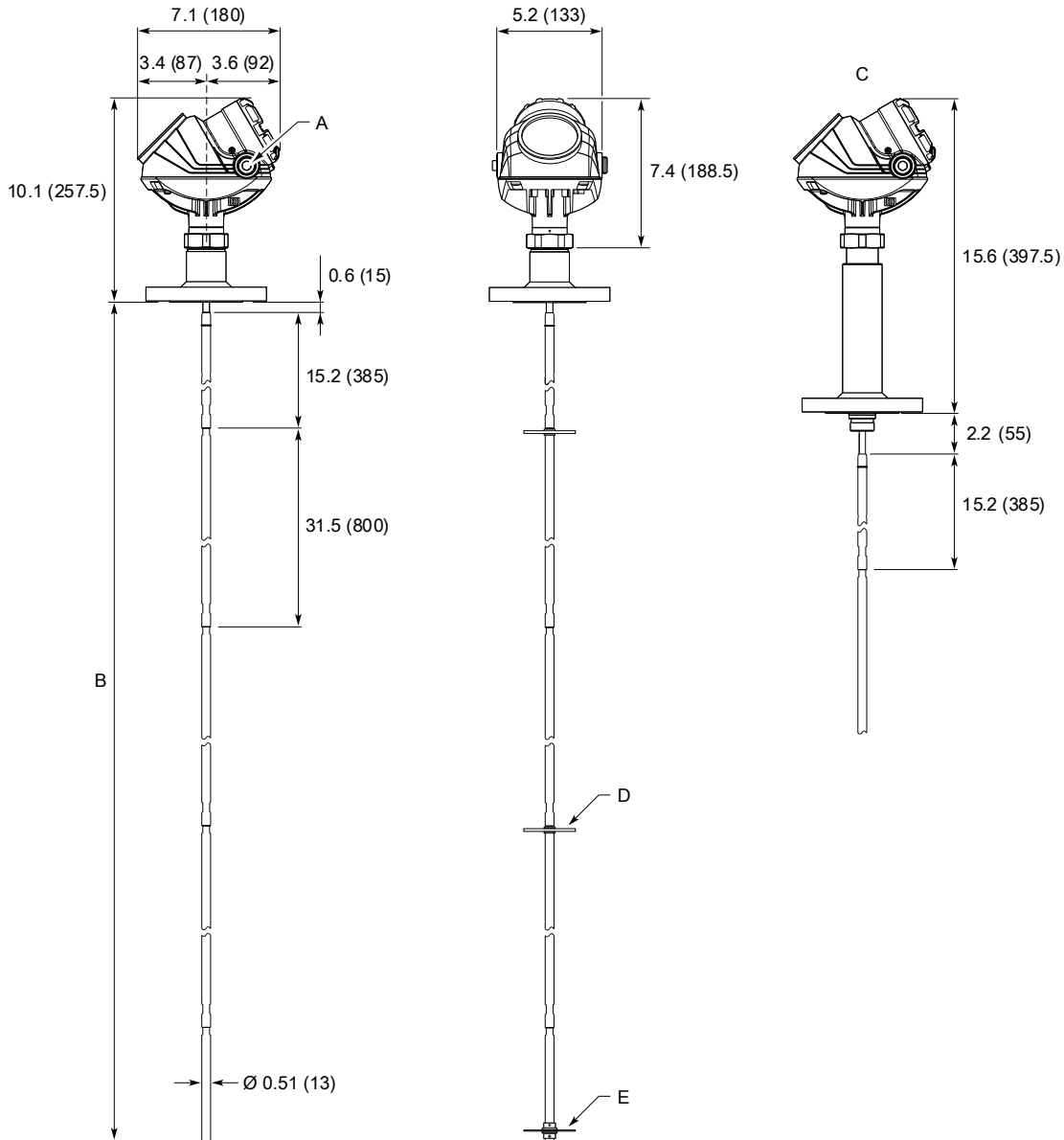

- A. 1/2 - 14 NPT; optional adapters: M20x1.5, eurofast and minifast
- B. L ≤ 33 ft. (10 m)
- C. HTHP/HP/C version
- D. Optional: PTFE centering disc
- E. Optional: Bottom centering disc (SST or PTFE)

Dimensions are in inches (millimeters).

Figure 36: Segmented Rigid Single Lead Probe with Threaded Connection

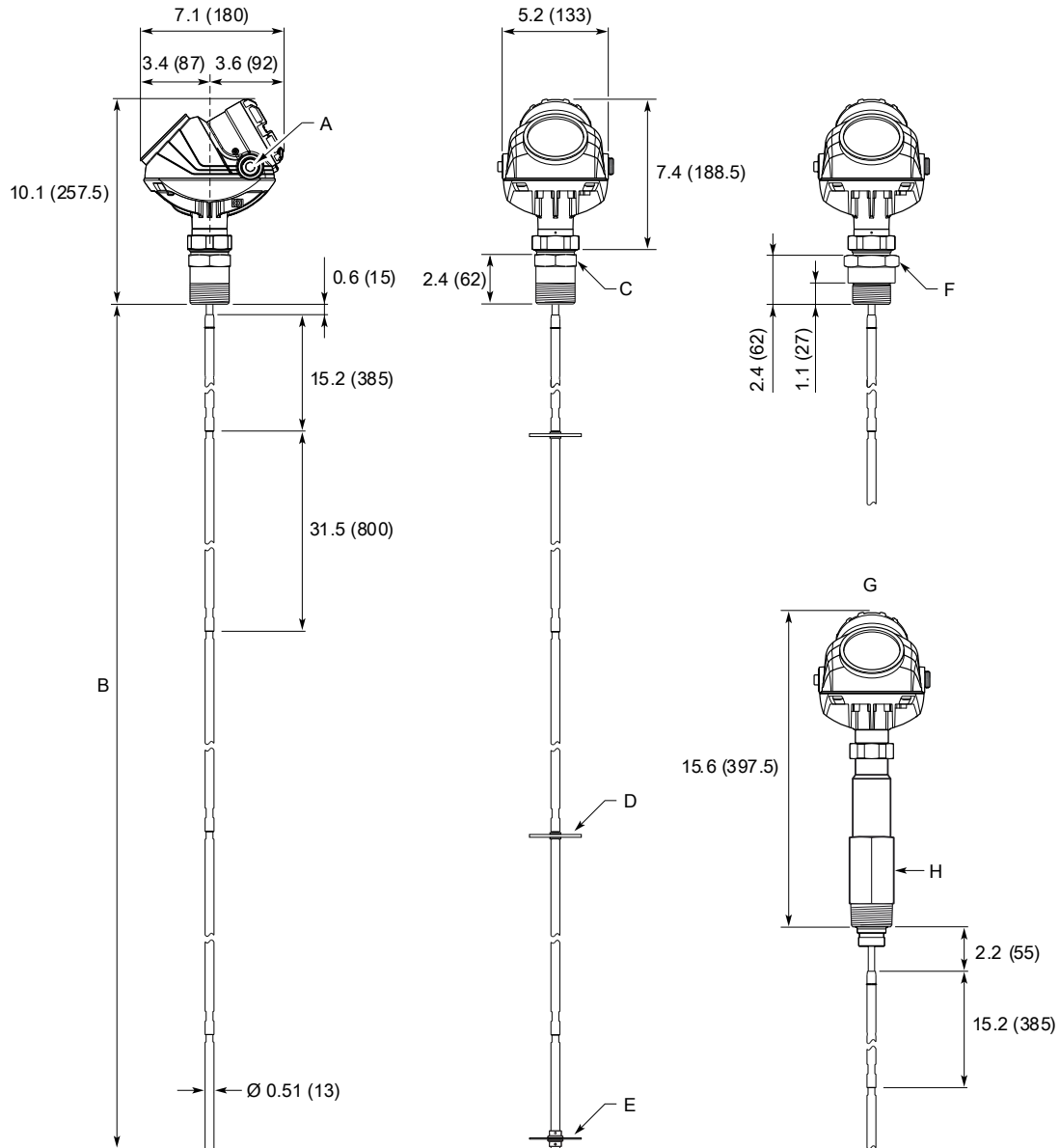

- A. ½ - 14 NPT; optional adapters: M20x1.5, eurofast and minifast
- B. L ≤ 33 ft. (10 m)
- C. NPT 1 in., s52; NPT 1½ in., s52; NPT 2 in., s60
- D. Optional: PTFE centering disc
- E. Optional: Bottom centering disc (SST or PTFE)
- F. BSP-G 1 in., s52; BSP-G 1½ in., s60
- G. HTHP/HP/C version
- H. NPT 1½ in., s50; BSP-G 1½ in., s60

Dimensions are in inches (millimeters).

Figure 37: Single Rigid Vapor Probe for 2-in. Chambers

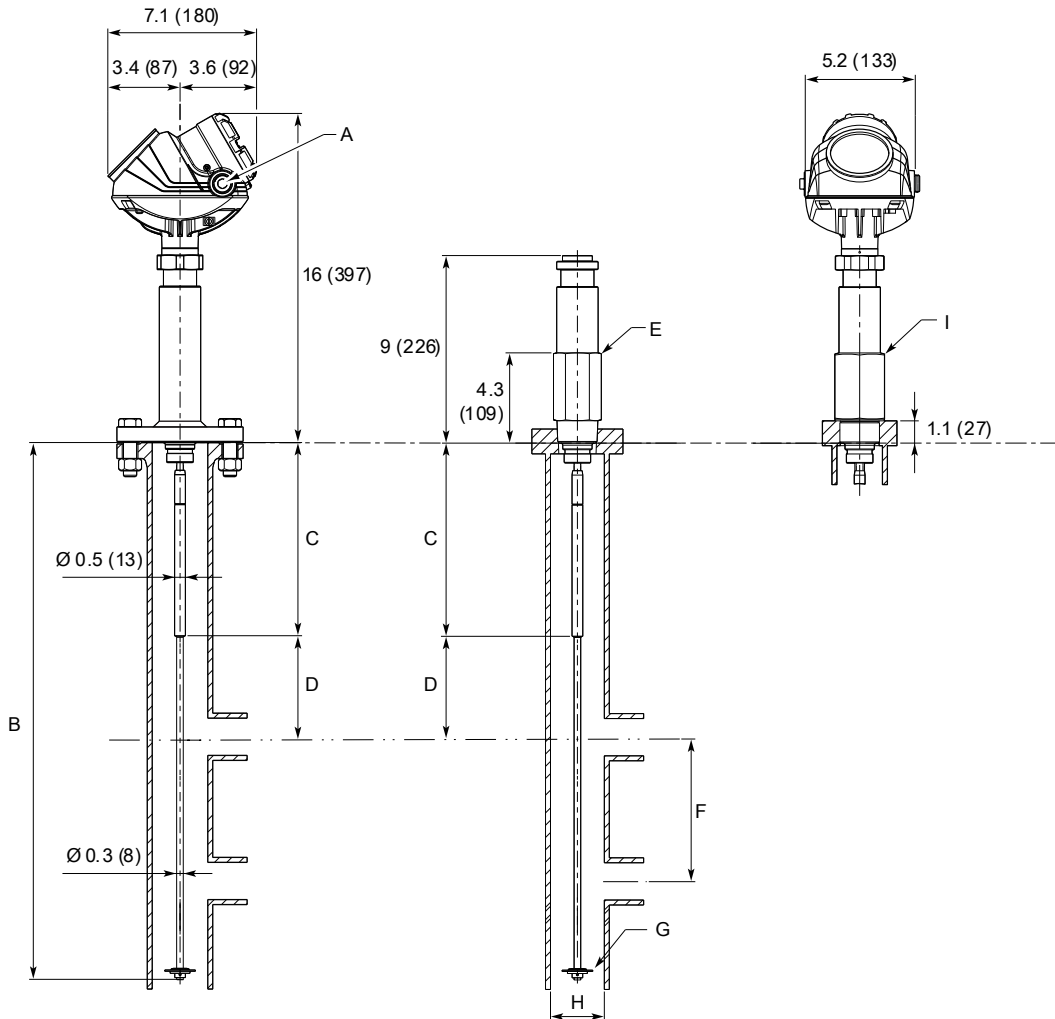

- A. 1/2 - 14 NPT; optional adapters: M20x1.5, eurofast and minifast
- B. $L \leq 10$ ft. (3 m)
- C. Short reflector: 13.8 (350); Long reflector: 19.7 (500)
- D. Minimum 8.3 in. (210 mm) distance between water surface and reflector end
- E. NPT 1 1/2 in., s50
- F. Min. 12 in. (300 mm)
- G. 1 1/2-in. centering disc, \varnothing 1.46 (37)
- H. Pipe inner diameter: \varnothing 1.5 (38) - \varnothing 2.05 (52)
- I. BSP-G 1 1/2 in., s60

Dimensions are in inches (millimeters).

Figure 38: Flexible Single Lead Probe with Flange Connection

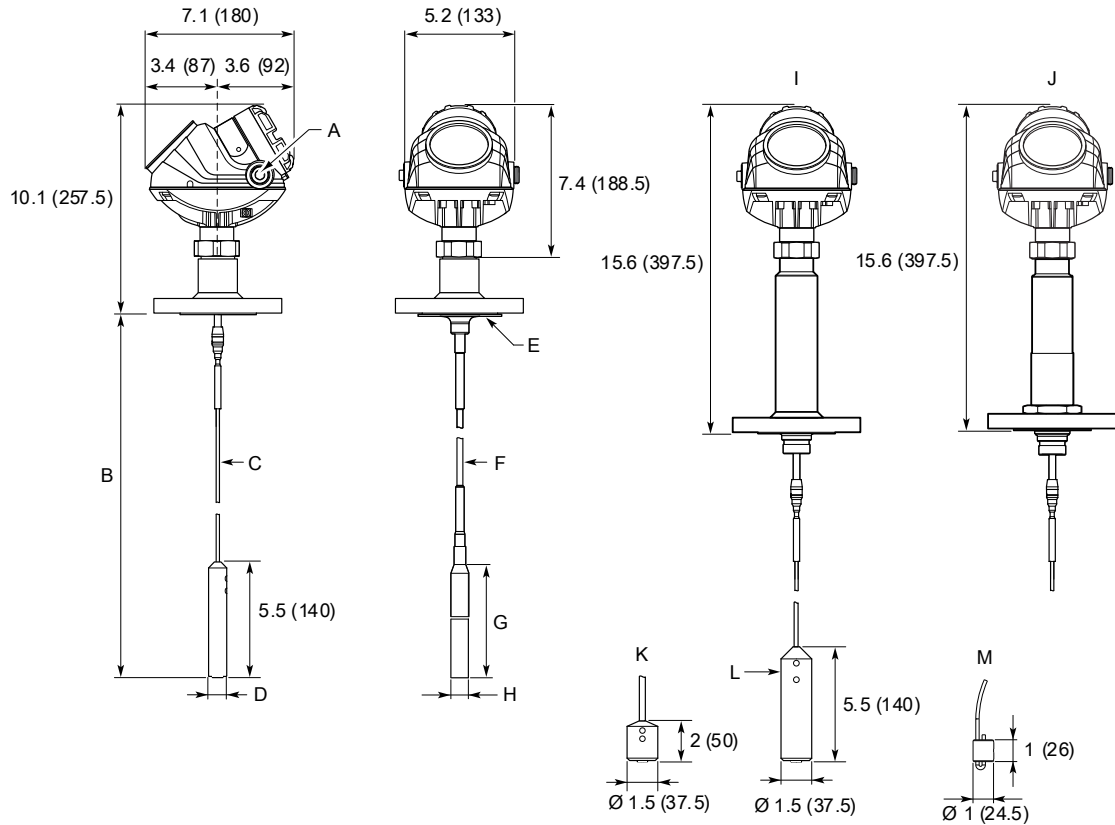

- A. 1/2 - 14 NPT; optional adapters: M20x1.5, eurofast and minifast
- B. L ≤ 164 ft. (50 m)
- C. Ø 0.16 (4); Ø 0.24 (6)
- D. 4 mm probe: Ø 0.86 (22); 6 mm probe: Ø 1.10 (28)
- E. The PTFE covered probe is designed with a protective plate
- F. Ø 0.28 (7) for PTFE covered probe
- G. 17.1 (434) for PTFE covered probe
- H. Ø 0.88 (22.5) for PTFE covered probe
- I. HTHP/HP/C version
- J. HTHP/HP/C Plate Design (Option for Alloy versions)
- K. Short weight (option W2)
- L. Heavy weight (option W3)
- M. Chuck

Dimensions are in inches (millimeters).

Figure 39: Flexible Single Lead Probe with Tri Clamp Connection

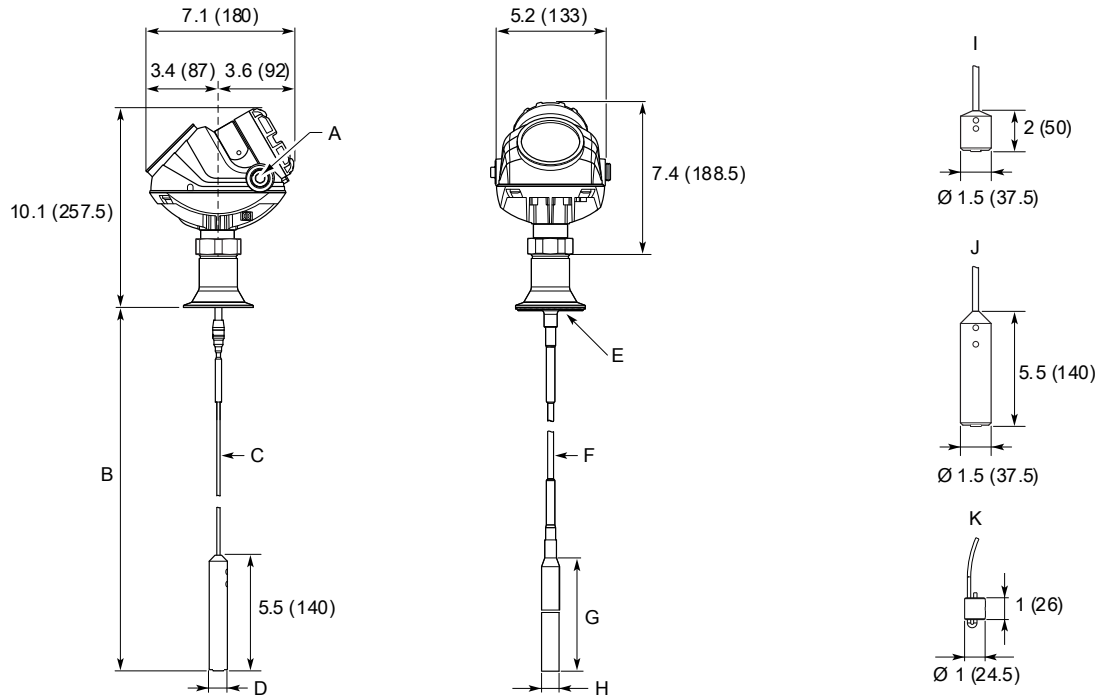

- A. 1/2 - 14 NPT; optional adapters: M20x1.5, eurofast and minifast
- B. $L \leq 164$ ft. (50 m)
- C. $\varnothing 0.16$ (4); $\varnothing 0.24$ (6)
- D. 4 mm probe: $\varnothing 0.86$ (22); 6 mm probe: $\varnothing 1.10$ (28)
- E. The PTFE covered probe is designed with a protective plate
- F. $\varnothing 0.28$ (7) for PTFE covered probe
- G. 17.1 (434) for PTFE covered probe
- H. $\varnothing 0.88$ (22.5) for PTFE covered probe
- I. Short weight (option W2)
- J. Heavy weight (option W3)
- K. Chuck

Dimensions are in inches (millimeters).

Figure 40: Flexible Single Lead with Threaded Connection

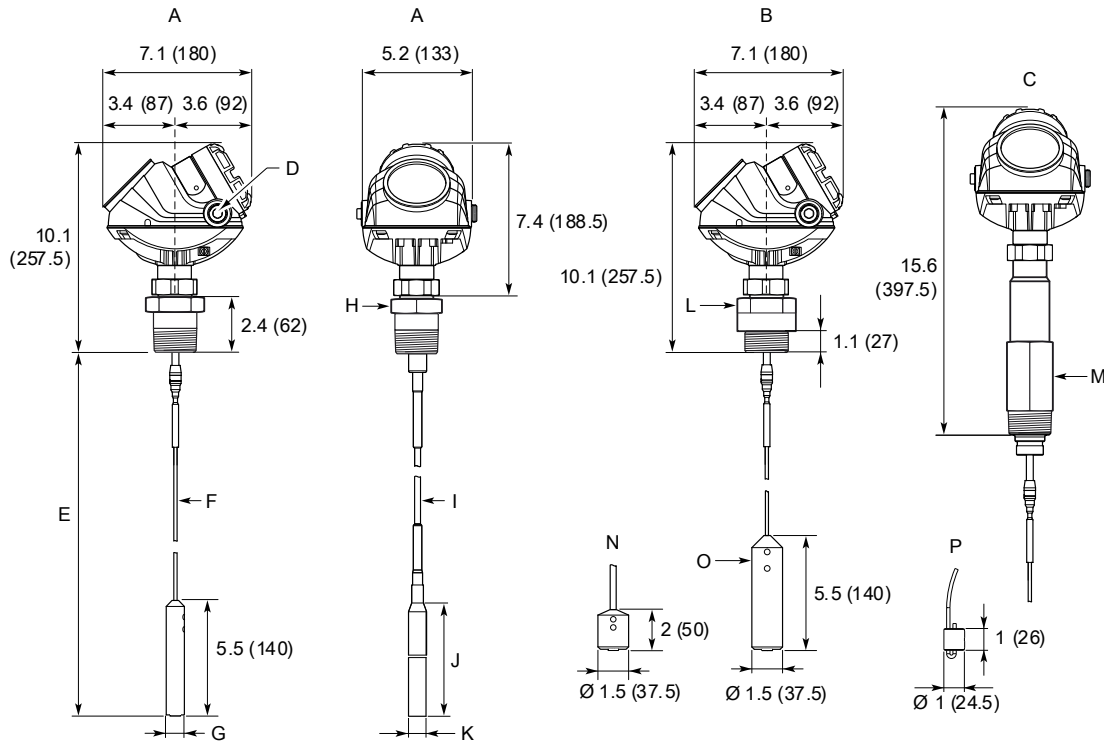

- A. NPT 1/1½/2 in.
- B. G 1/1½ in.
- C. NPT 1½, G 1½ in. (HTHP/HP/C version)
- D. ½ - 14 NPT; optional adapters: M20x1.5, eurofast and minifast
- E. L ≤ 164 ft. (50 m)
- F. Ø 0.16 (4); Ø 0.24 (6)
- G. 4 mm probe: Ø 0.86 (22); 6 mm probe: Ø 1.10 (28)
- H. 1 in. / 1½ in.: s52; 2 in.: s60
- I. Ø 0.28 (7) for PTFE covered probe
- J. 17.1 (434) for PTFE covered probe
- K. Ø 0.88 (22.5) for PTFE covered probe
- L. 1 in.: s52; 1½ in.: s60
- M. NPT: s50; G: s60
- N. Short weight (option W2)
- O. Heavy weight (option W3)
- P. Chuck

Dimensions are in inches (millimeters).

Figure 41: Coaxial probe with Flange Connection

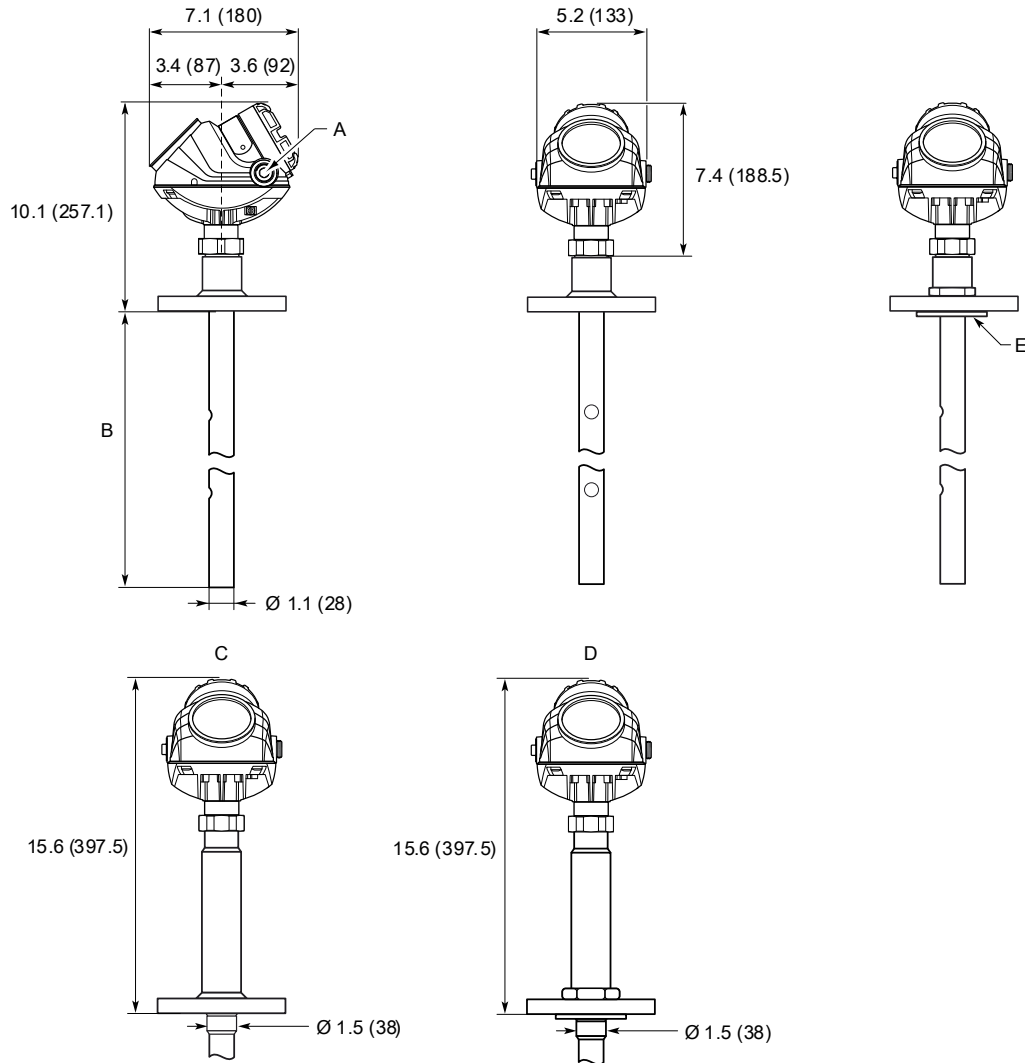

- A. 1/2 - 14 NPT; optional adapters: M20x1.5, eurofast and minifast
- B. L ≤ 20 ft. (6 m)
- C. HTHP/HP/C version
- D. HTHP/HP Plate Design (Option for Alloy versions)
- E. The Alloy probes are designed with a protective plate

Dimensions are in inches (millimeters).

Figure 42: Coaxial Probe with Threaded Connection

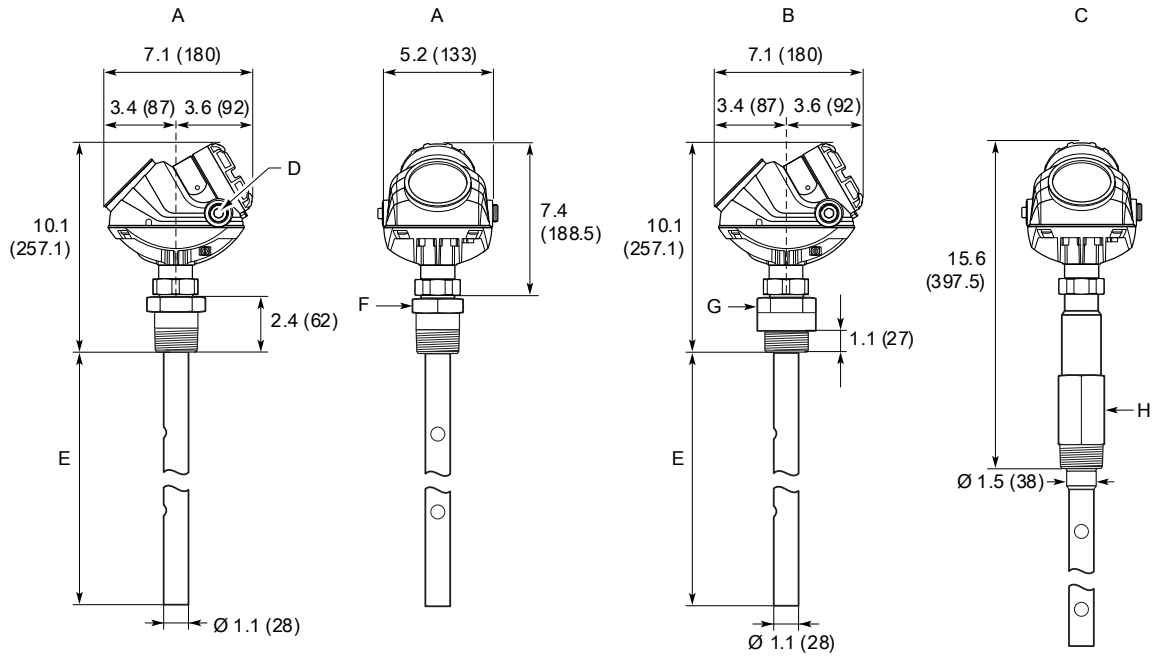

- A. NPT 1/1½/2 in.
- B. G 1/1½ in.
- C. NPT 1½, G 1½ inch (HTHP/HP/C version)
- D. ½ - 14 NPT; optional adapters: M20x1.5, eurofast and minifast
- E. L ≤ 20 ft (6 m)
- F. 1 in., 1½ in.: s52; 2 in.: s60
- G. 1 in.: s52; 1½ in.: s60
- H. NPT: s50; G: s60

Dimensions are in inches (millimeters).

Figure 43: Large Coaxial Probe with Flange Connection

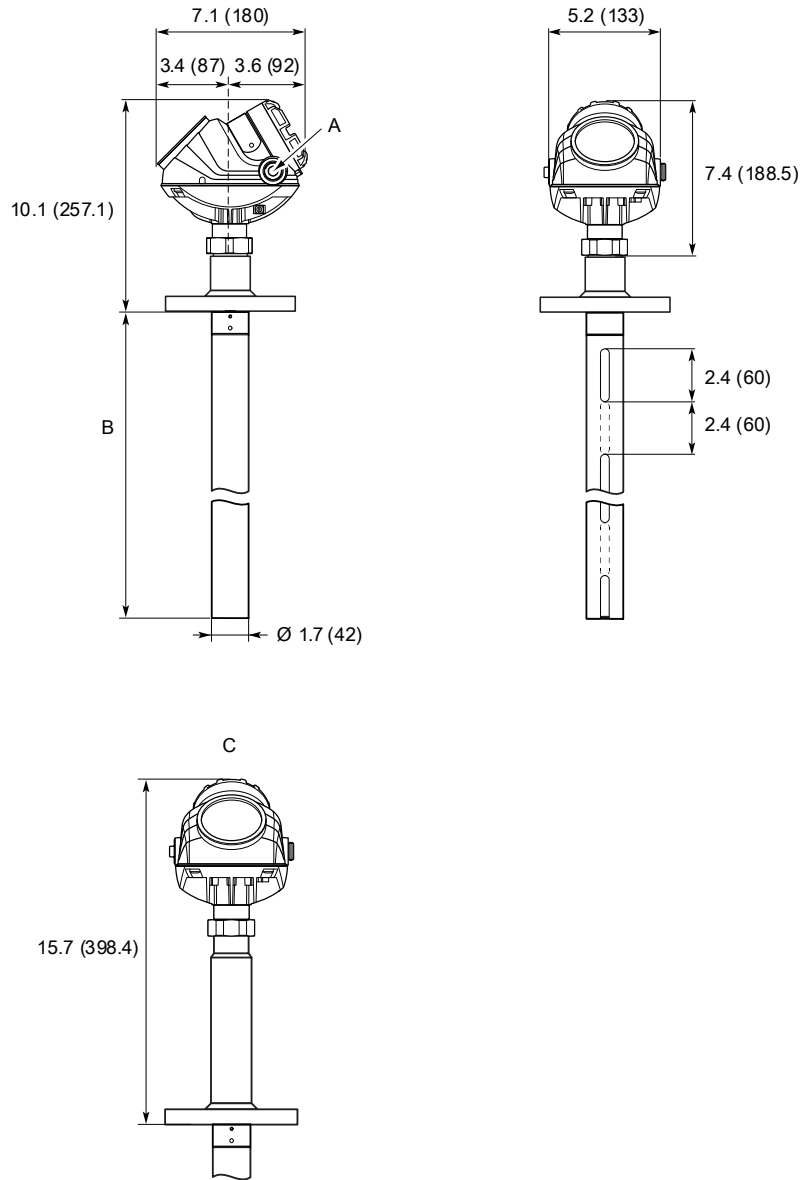

- A. 1/2 - 14 NPT; optional adapters: M20x1.5, eurofast and minifast
- B. $L \leq 20$ ft. (6 m)
- C. HP/C version

Dimensions are in inches (millimeters).

Figure 44: Large Coaxial Probe with Threaded Connection

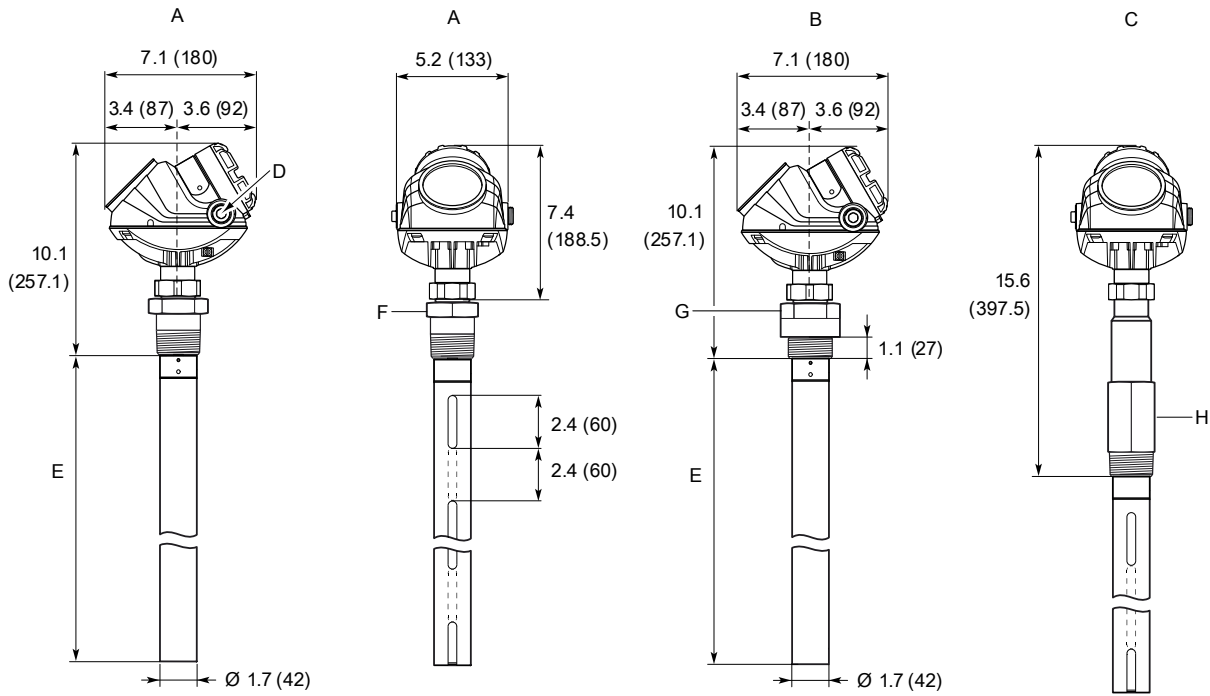

- A. NPT 1½ in.
- B. G 1½ in.
- C. NPT 1½, G 1½ in. (HP/C version)
- D. ½ - 14 NPT; optional adapters: M20x1.5, eurofast and minifast
- E. L ≤ 20 ft. (6 m)
- F. 1½ in.: s52; 2 in.: s60
- G. 1½ in.: s60
- H. NPT: s50; G: s60

Dimensions are in inches (millimeters).

Figure 45: Integrated Still Pipe Vapor Probe for 3-in. Chambers and above

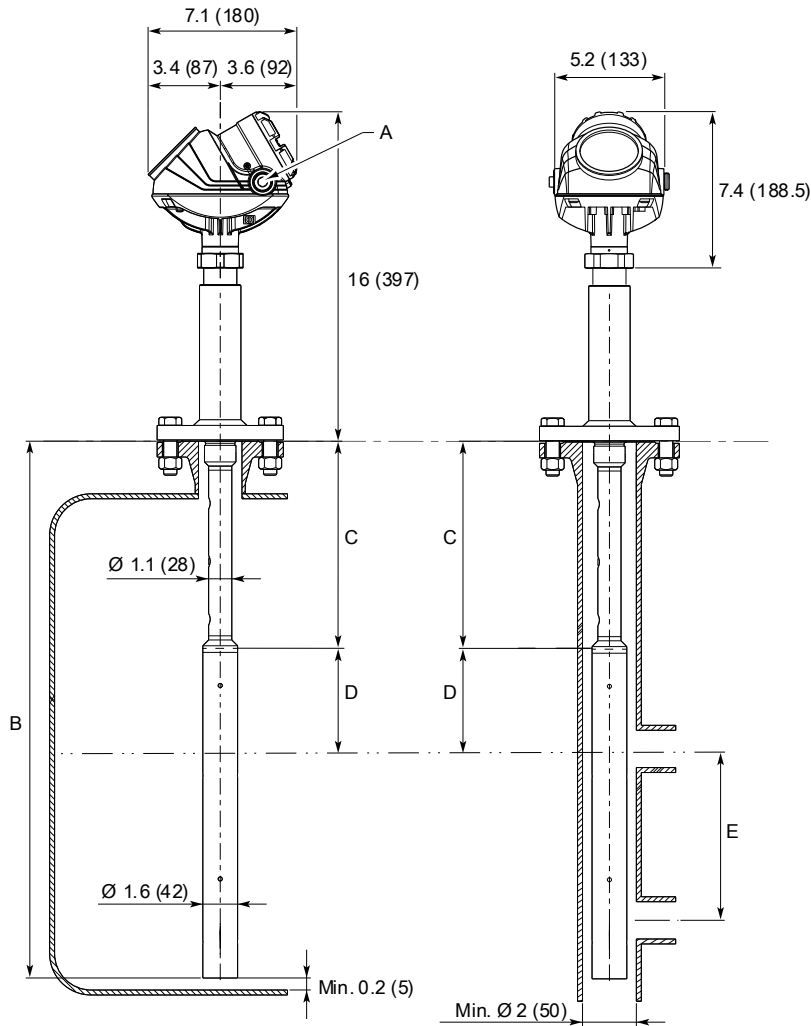

- A. 1/2 - 14 NPT; optional adapters: M20x1.5, eurofast and minifast
- B. $L \leq 13 \text{ ft. } 1 \text{ in. } (4 \text{ m})$
- C. Short reflector: 13.8 (350); Long reflector: 19.7 (500)
- D. Minimum 8.3 in. (210 mm) distance between water surface and reflector end
- E. Minimum 12 in. (300 mm)

Dimensions are in inches (millimeters).

Figure 46: Rigid Twin Lead Probe

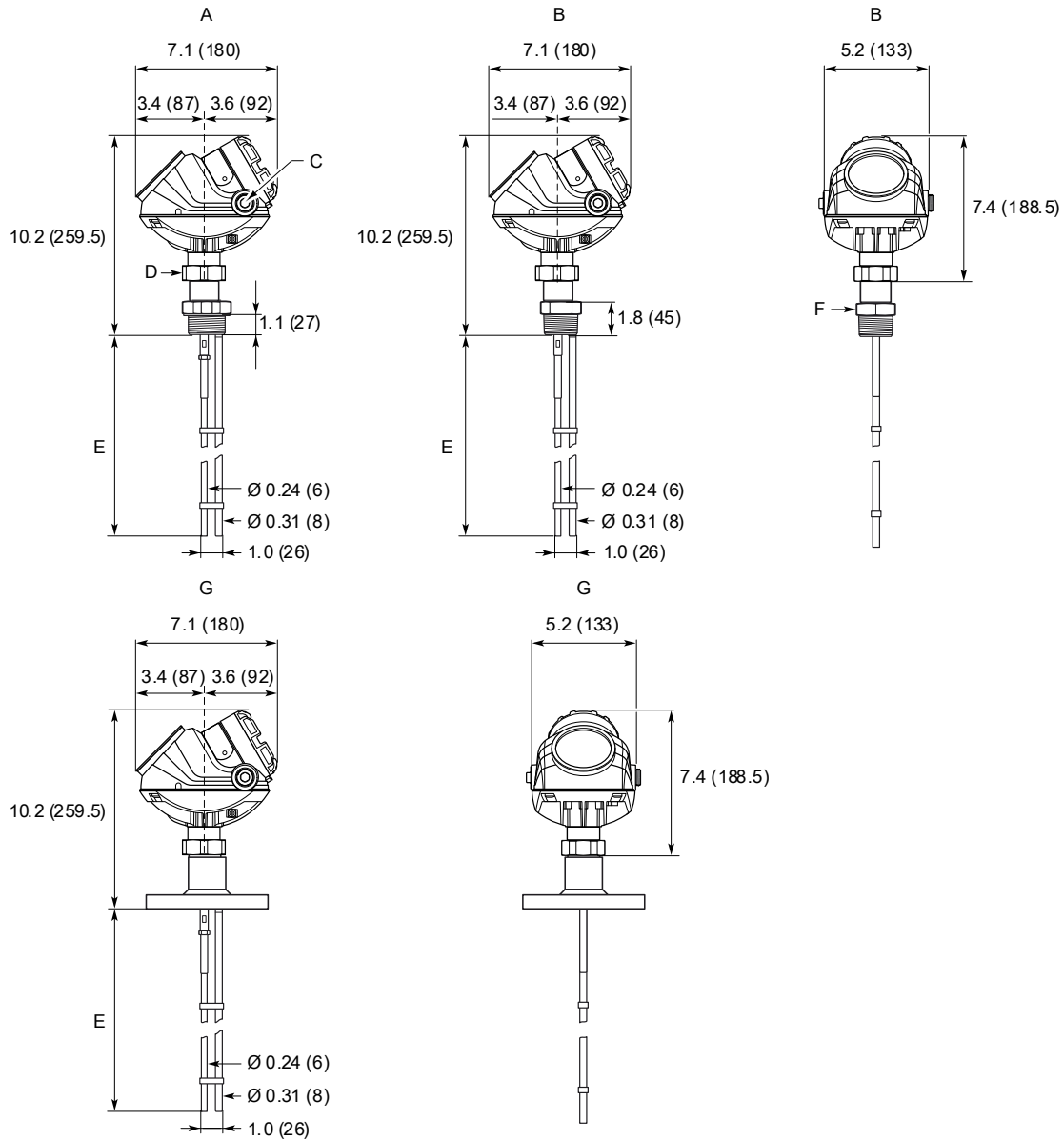

- A. G 1½ in.
- B. NPT 1½ / 2 in.
- C. ½ - 14 NPT; optional adapters: M20x1.5, eurofast and minifast
- D. s60
- E. L ≤ 10 ft. (3 m)
- F. 1½ in.: s52; 2 in.: s60
- G. Flange

Dimensions are in inches (millimeters).

Figure 47: Flexible Twin Lead Probe

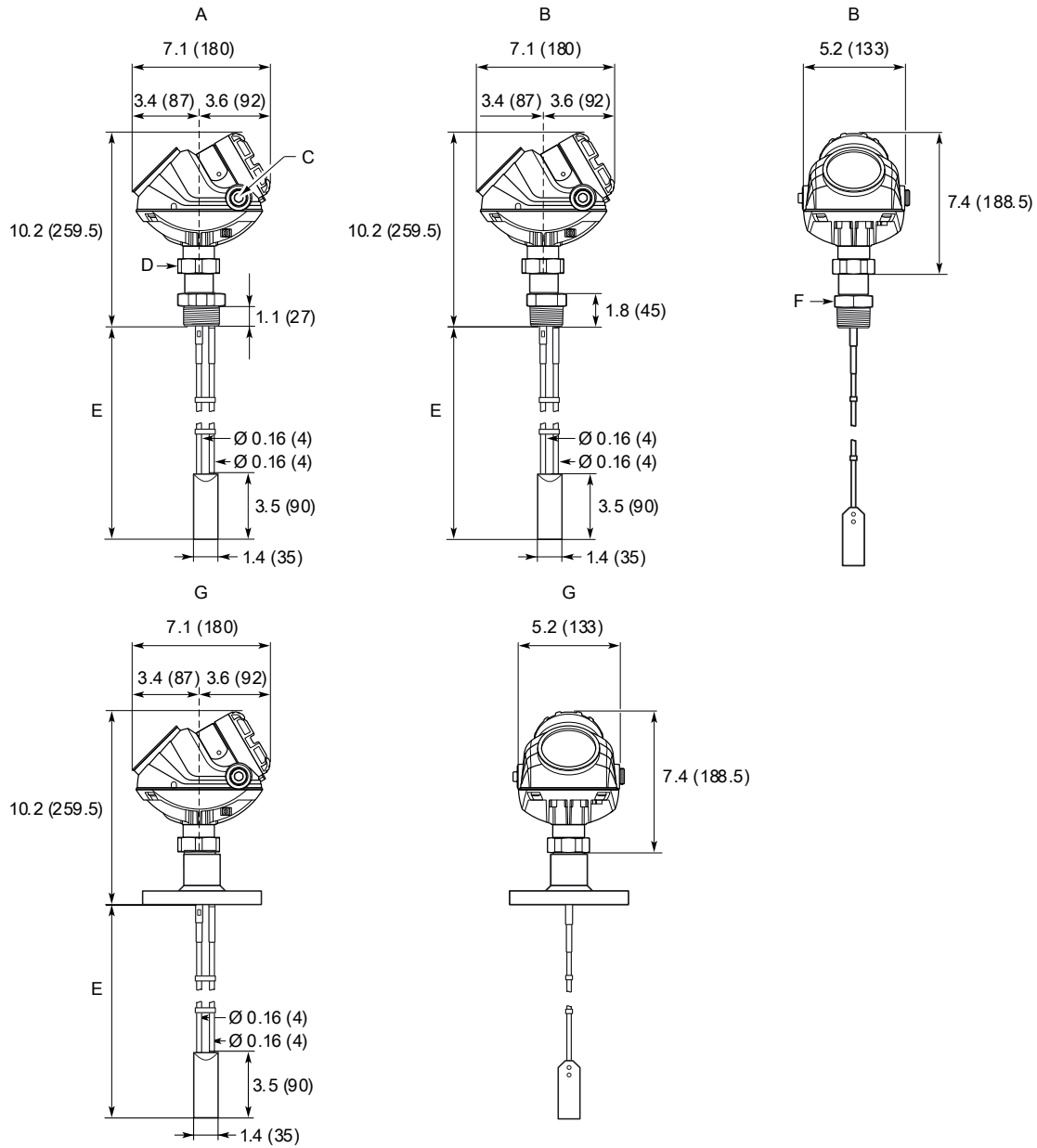

- A. G 1½ in.
- B. NPT 1½ / 2 in.
- C. ½ - 14 NPT; optional adapters: M20x1.5, eurofast and minifast
- D. s60
- E. L ≤ 164 ft. (50 m)
- F. 1½ in.: s52; 2 in.: s60
- G. Flange

Dimensions are in inches (millimeters).

Figure 48: Mounting Bracket (Option Code BR)

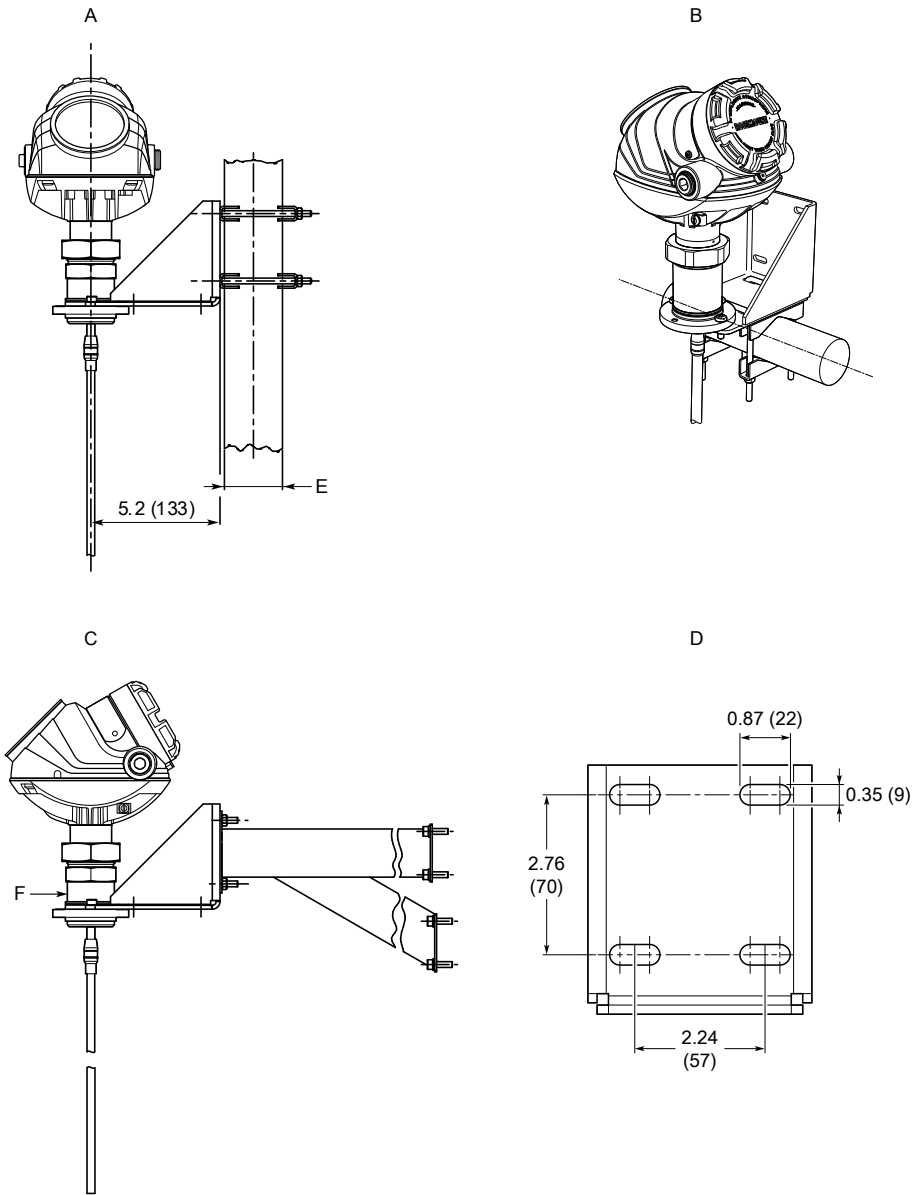

- A. Pipe mounting (vertical pipe)
- B. Pipe mounting (horizontal pipe)
- C. Wall mounting
- D. Hole pattern for wall mounting
- E. Pipe diameter: max 2.5 in. (64 mm)
- F. NPT 1½-in.

Dimensions are in inches (millimeters).

Figure 49: Remote Housing (Option Code B1, B2, B3)

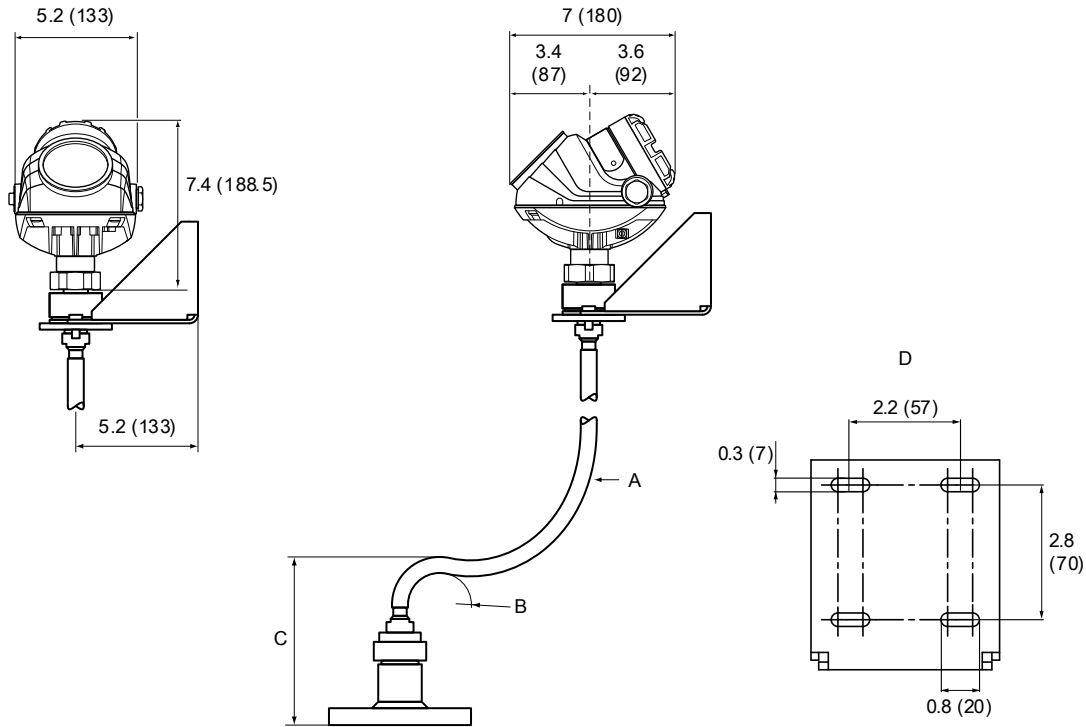

- A. 3, 6, 9 ft. (1, 2, or 3 m)
- B. R_{min} : 1.4 (35)
- C. H_{min} : 6.9 (175) for Standard variant; 12.4 (315) for HTHP/HP/C variant
- D. Hole pattern for remote housing wall mounting

Dimensions are in inches (millimeters).

Figure 50: Heat Sink (Option Code HS)

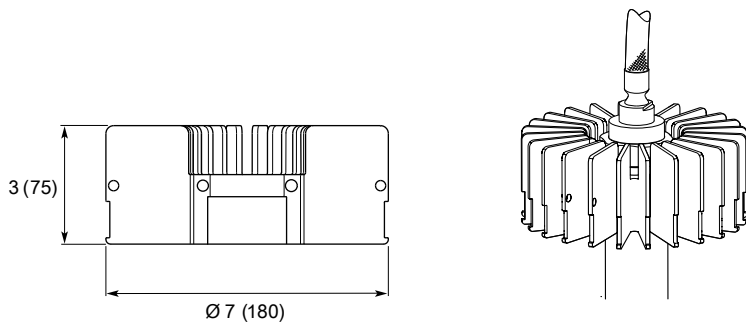

Dimensions are in inches (millimeters).

Proprietary flanges

Figure 51: Proprietary Flanges

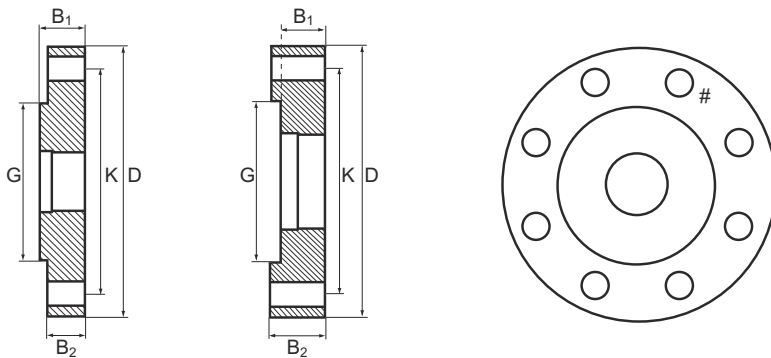

D: Outside diameter

B₁: Flange thickness with gasket surface

B₂: Flange thickness without gasket surface

F=B₁-B₂: Gasket surface thickness

G: Gasket surface diameter

Bolts: Number of bolts

K: Bolt hole circle diameter

Dimensions are in inches (millimeters).

Note

Dimensions may be used to aid in the identification of installed flanges. It is not intended for manufacturing use.

Table 40: Dimensions of Proprietary Flanges

Special flanges ⁽¹⁾	D	B ₁	B ₂	F	G	# Bolts	K
Fisher™ 249B/259B ⁽²⁾	9.00 (228.6)	1.50 (38.2)	1.25 (31.8)	0.25 (6.4)	5.23 (132.8)	8	7.25 (184.2)
Fisher 249C ⁽³⁾	5.69 (144.5)	0.94 (23.8)	1.13 (28.6)	-0.19 (-4.8)	3.37 (85.7)	8	4.75 (120.65)
Masoneilan™ ⁽²⁾	7.51(191.0)	1.54 (39.0)	1.30 (33.0)	0.24 (6.0)	4.02 (102.0)	8	5.87 (149.0)

(1) These flanges are also available in a vented version. Vented flanges must be ordered with a 1½-in. NPT threaded process connection (code RA).

(2) Flange with raised face.

(3) Flange with recessed face.

For information about flange temperature and pressure ratings, see [Fisher and Masoneilan flange rating](#).

Flushing connection rings

Figure 52: Flushing Connection Rings

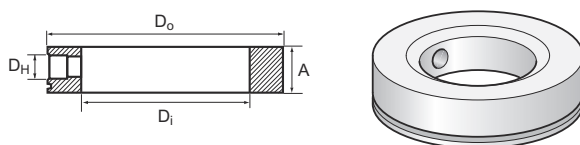

A. Height: 0.97 in. (24.6 mm)

Table 41: Dimensions of Flushing Connection Rings

Flushing connection rings	D _i	D _o	D _H
2-in. ANSI ⁽¹⁾	2.12 (53.8)	3.62 (91.9)	¼-in. NPT
3-in. ANSI ⁽¹⁾	3.60 (91.4)	5.00 (127.0)	¼-in. NPT
4-in. ANSI ⁽¹⁾ /DN100	3.60 (91.4)	6.20 (157.5)	¼-in. NPT
DN50	2.40 (61.0)	4.00 (102.0)	¼-in. NPT
DN80	3.60 (91.4)	5.43 (138.0)	¼-in. NPT

(1) Up to Class 2500.

Emerson Automation Solutions

6021 Innovation Blvd.
Shakopee, MN 55379, USA
📞 +1 800 999 9307 or +1 952 906 8888
📠 +1 952 949 7001
✉️ RFQ.RMD-RCC@Emerson.com

North America Regional Office

Emerson Automation Solutions
8200 Market Blvd.
Chanhassen, MN 55317, USA
📞 +1 800 999 9307 or +1 952 906 8888
📠 +1 952 949 7001
✉️ RMT-NA.RCCRFQ@Emerson.com

Latin America Regional Office

Emerson Automation Solutions
1300 Concord Terrace, Suite 400
Sunrise, FL 33323, USA
📞 +1 954 846 5030
📠 +1 954 846 5121
✉️ RFQ.RMD-RCC@Emerson.com

Europe Regional Office

Emerson Automation Solutions Europe
GmbH
Neuhofstrasse 19a P.O. Box 1046
CH 6340 Baar
Switzerland
📞 +41 (0) 41 768 6111
📠 +41 (0) 41 768 6300
✉️ RFQ.RMD-RCC@Emerson.com

Asia Pacific Regional Office

Emerson Automation Solutions
1 Pandan Crescent
Singapore 128461
📞 +65 6777 8211
📠 +65 6777 0947
✉️ Enquiries@AP.Emerson.com

Middle East and Africa Regional Office

Emerson Automation Solutions
Emerson FZE P.O. Box 17033
Jebel Ali Free Zone - South 2
Dubai, United Arab Emirates
📞 +971 4 8118100
📠 +971 4 8865465
✉️ RFQ.RMTMEA@Emerson.com

 [Linkedin.com/company/Emerson-Automation-Solutions](https://www.linkedin.com/company/Emerson-Automation-Solutions)

 [Twitter.com/Rosemount_News](https://twitter.com/Rosemount_News)

 [Facebook.com/Rosemount](https://www.facebook.com/Rosemount)

 [Youtube.com/user/RosemountMeasurement](https://www.youtube.com/user/RosemountMeasurement)

©2021 Emerson. All rights reserved.

Emerson Terms and Conditions of Sale are available upon request. The Emerson logo is a trademark and service mark of Emerson Electric Co. Rosemount is a mark of one of the Emerson family of companies. All other marks are the property of their respective owners.